

# B4.1

#9038 RC10B4.1 RTR

#9039 RC10B4.1 Brushless RTR



# T4.1

#7036 RC10T4.1 RTR

#7037 RC10T4.1 Brushless RTR



1:10 Scale Ready-To-Run Electric 2WD Off Road Manual

11/09

# TEAM ASSOCIATED



## :: Introduction

Thank you for purchasing this Team Associated product. This manual contains instructions and tips for building and maintaining your new T4.1 or B4.1. Please take a moment to read through it and familiarize yourself with these steps. We are continually changing and improving our designs; therefore, actual parts may appear slightly different than the illustrations. New parts will be noted on supplementary sheets located in the appropriate parts bags. Check each bag for these sheets before you start to build.

## :: T4.1 Features

### Chassis:

- Built on 7-time National Champion RC10 T4 Platform
- Screen printed Interceptor- T 0.030" thickness polycarbonate body
- 2.6:1 Ratio Gearbox equipped with sealed gear differential
- Dual-sided externally adjustable slipper clutch
- Molded composite low-CG chassis
- Battery Strap with twist-lock thumb knobs. No more body clips!
- 5-40 set-screw to lock antenna tube in place
- Complete set of 14 rubber sealed ball bearings
- Rugged adjustable steel turnbuckles
- Fully adjustable caster, camber, and toe-in
- Angled bellcrank "co-planar" steering
- Built in servo saver
- Vertical ball end adjustment, front & rear
- Updated with easy to use 2mm hex ballstuds in 14 locations
- Blue aluminum shock bodies with molded pre-load clips
- Dogbone rear axles
- Pre-mounted tires on white dish wheels

### Electronics:

- XP3-SS 2.4 GHz 3-Channel Radio System
- SHV1504 MG Metal Gear Servo

### Brushed T4.1:

- XP SC200 Electronic Speed Control
- Radon 17 Turn Motor

### Brushless T4.1:

- XP SC450-BL Brushless Electronic Speed Control
- Reedy 3300kV Brushless Motor

### Other Notables:

- Wheelbase= 288 mm
- Width= 316 mm
- Total length = 390 mm

## :: B4.1 / T4.1 RTR

Your new T4.1 / B4.1 RTR comes factory assembled including radio gear, motor, and ESC. However, there are some items you will need to complete your kit (refer to catalog for suggestions):

- AA-size batteries for transmitter (x8)
- 6 cell NiMH battery pack or 2 cell LiPo battery pack
- Battery charger (we recommend a peak detection charger)

### Tools included:

- Allen wrenches #6950 (.050", 1/16", 3/32", 5/64")
- 1.5mm allen wrench • Molded tools #6956
- Camber gauge #1719 • Shock building tool #6429

## :: B4.1 Features

### Chassis:

- Built on 4-time World Champion and 5-time National Champion RC10 B4 platform.
- Screen printed Interceptor 2.0 0.040" thickness polycarbonate body
- High-downforce 6.5" wing
- 2.6:1 Ratio Gearbox equipped with sealed gear differential
- Dual-sided externally adjustable slipper clutch
- Molded composite low-CG chassis
- Revised shock towers for increased durability
- Battery Strap with twist-lock thumb knobs. No more body clips!
- 5-40 set-screw to lock antenna tube in place
- Complete set of 14 rubber sealed ball bearings
- Rugged adjustable steel turnbuckles
- Fully adjustable caster, camber, and toe-in
- Angled bellcrank "co-planar" steering
- Built in servo saver
- Vertical ball end adjustment, front & rear
- Updated with easy to use 2mm hex ballstuds in 14 locations
- Blue aluminum shock bodies with molded pre-load clips
- Dogbone rear axles
- Pre-mounted tires on white dish wheels

### Electronics:

- XP3-SS 2.4 GHz 3-Channel Radio System
- SHV1504 MG Metal Gear Servo

### Brushed B4.1:

- XP SC200 Electronic Speed Control
- Radon 17 Turn Motor

### Brushless B4.1:

- XP SC450-BL Brushless Electronic Speed Control
- Reedy 3300kV Brushless Motor

### Other Notables:

- Wheelbase= 273 mm
- Width= 250 mm
- Total length = 377 mm

## :: Notes



\* These Symbols Indicate a special note or instructions.

**There is a 1:1 fold out in the back of the manual. Fold it out while building your kit for easy parts sizing!**

**Associated Electrics, Inc.**  
26021 Commercentre Dr.  
Lake Forest, CA 92630



**Customer Service**  
Tel: 949.544.7500  
Fax: 949.544.7501

<http://www.TeamAssociated.com> • <http://www.RC10.com> • [http://twitter.com/Team\\_Associated](http://twitter.com/Team_Associated) • <http://bit.ly/AEonFacebook>

**:: Steering Rack Build**

**BAG A T41 & B41**

**A2**  
STEP 1

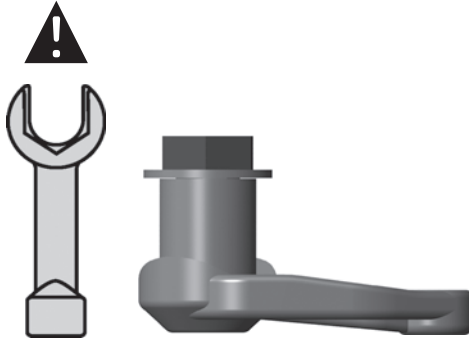
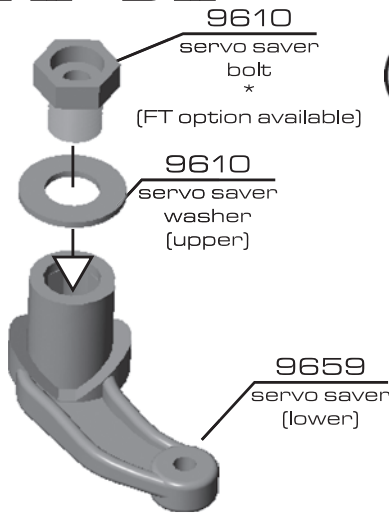

\* With supplied wrench, tighten servo saver bolt completely, **until it hits bottom**. Do not over tighten.

**Remove** bolt and washer; continue assembly per instructions.

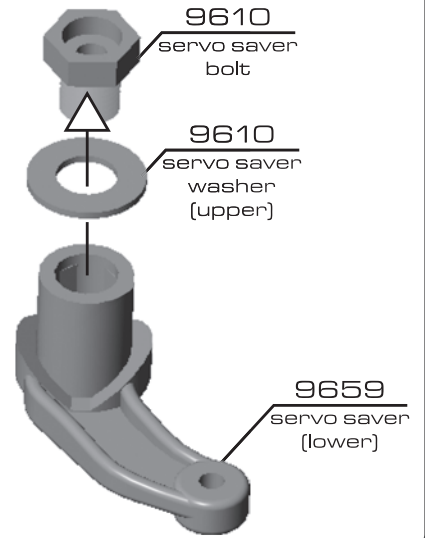

**:: Steering Rack Build (cont.)**

**A2**  
STEP 2

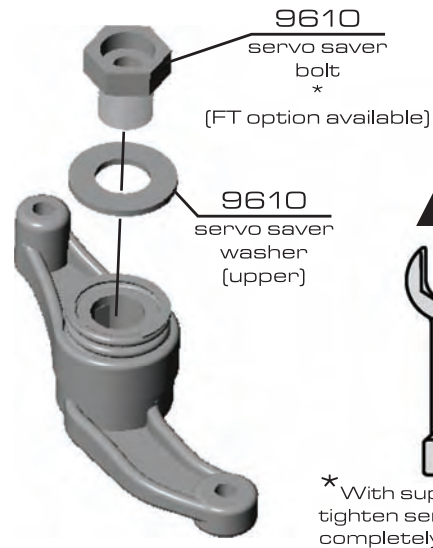
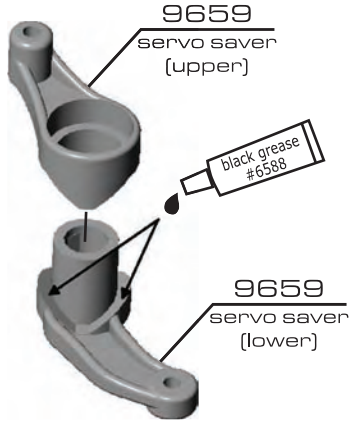

\* With supplied wrench, tighten servo saver bolt completely, but take care not to overtighten.

**:: Steering Rack Build (cont.)**

**A 2/3**  
STEP 3

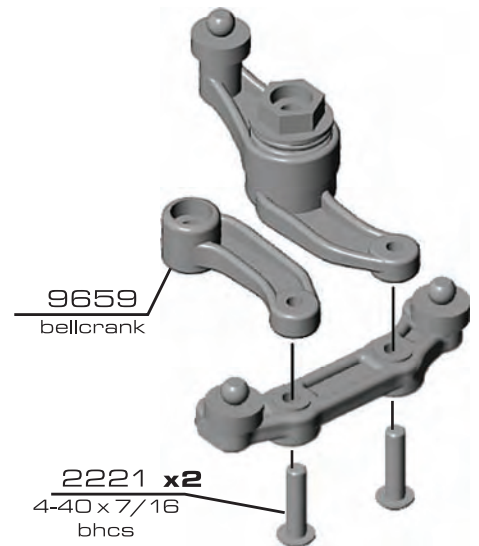
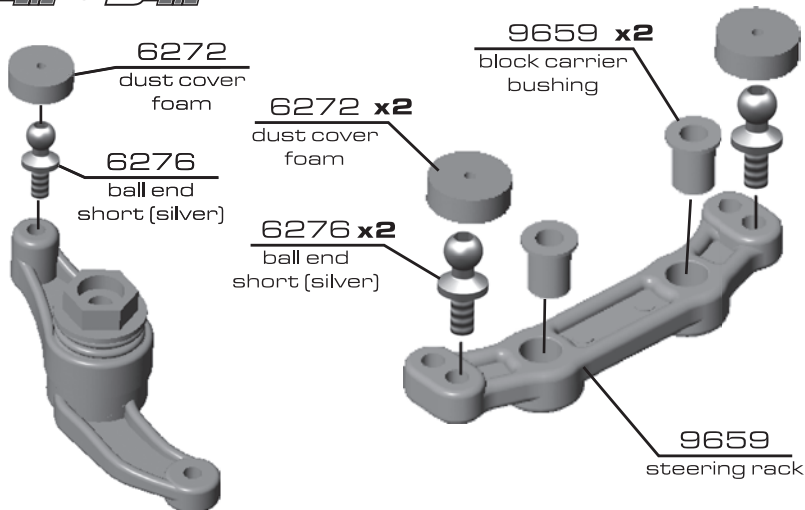

**2221 x2**  
4-40 x 7/16  
bhcs

**:: Steering Rack Build (cont.)**

**A 4/5** *T41 & B41*  
STEP 4

9566  
top plate

3856 x4  
steering rack  
bushing  
\*  
(FT option available)

9640  
steering bolt  
(right)

9659  
steering  
brace

9640  
steering bolt  
(left)

9563  
front  
bulkhead  
\*  
(FT option available)

T4 - 7440  
B4 - 9560  
chassis

6925 x3  
4-40 x 1/2  
shcs

6915 x2  
4-40 x 5/8  
fhcs



\* Do not overtighten steering bolts. Make sure there is free movement in the steering rack.

**:: Steering Knuckles Build**

**BAG B** *T41 & B41*

**B 2**  
STEP 1

6272 x2  
dust cover  
foam

7260 x2  
4-40 small  
plain nut

3983 x2  
ball end  
long (black)

4187 x2  
.030 washer

6277 x2  
ball end  
long (silver)

9580 x2  
caster block  
1 left & 1 right  
(25°)

6272 x2  
dust cover  
foam

9581 x2  
steering block  
1 left & 1 right

6299 x2  
e-clip

9613 x2  
trailing  
axle

**RIGHT**

**LEFT**

**RIGHT**

**LEFT**

**:: Steering Knuckles Build (cont.)**

**B 2** *T41 & B41*  
STEP 2

**RIGHT**

**LEFT**

9622 x2  
kingpin

9645 x2  
2-56 x 1/8  
bhcs

4187 x4  
.030 washer

**RIGHT**

**LEFT**

**:: Front End**

**B 3**  
STEP 3

**T41**

9645 x2  
2-56 x 1/8  
bhcs

9622 x2  
hinge pin  
front outer

9580 x2  
spacer

**T4 Front A-Arm**  
**LEFT**

7446 x2  
A-arms, front

**T4 Front A-Arm**  
**RIGHT**

9580 x2  
spacer

9622 x2  
hinge pin  
front outer

9645 x2  
2-56 x 1/8  
bhcs

**B41**

**B4 Front A-Arm**  
**RIGHT**

9578 x2  
B4 A-arms, front  
\*

(FT option available)

**B4 Front A-Arm**  
**LEFT**

**:: Front End (cont.)**

**B 4**  
STEP 4

**T41 & B41**

9621 x2  
hinge pin  
front inner

4334 x2  
2-56 x 5/16  
bhcs

9564  
front hinge  
pin brace  
\*

**T41**

(FT option available)

9645 x2  
2-56 x 1/8  
bhcs

**B41**

6915 x2  
4-40 x 5/8  
fhcs

9562  
front  
bumper

**:: Front End (cont.)**

**B 4**  
STEP 5

**T41**

7738 x2  
4-40 x 7/8  
shcs

6277 x2  
ball end  
long (silver)

9630 x2  
washer

7439 x2  
front body  
mount

9825  
front shock  
tower

6272 x2  
dust cover  
foam

6924 x2  
4-40 x 3/8  
shcs

9568  
B4 front  
shock tower

6295 x2  
4-40  
plain nut

**B41**

7738 x2  
4-40 x 7/8  
shcs

6295 x2  
4-40  
plain nut

9630 x2  
washer

6272 x2  
dust cover  
foam

6277 x2  
ball end  
long (silver)

**:: Front End (cont.)**

**B5**  
STEP 6

**T4.1**

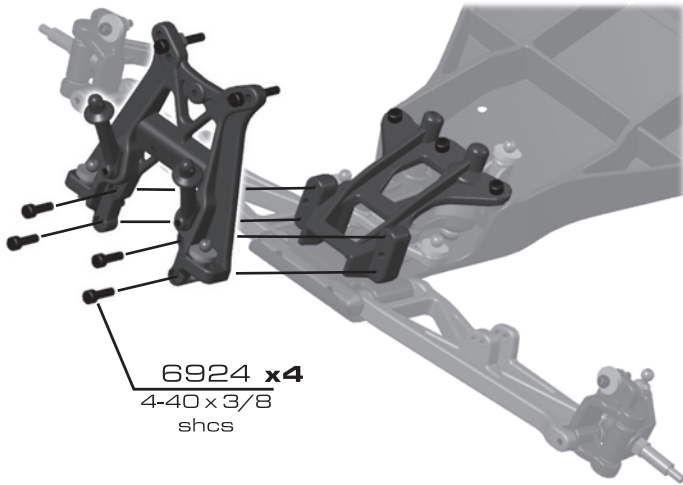

6924 x4  
4-40 x 3/8  
shcs

**B4.1**

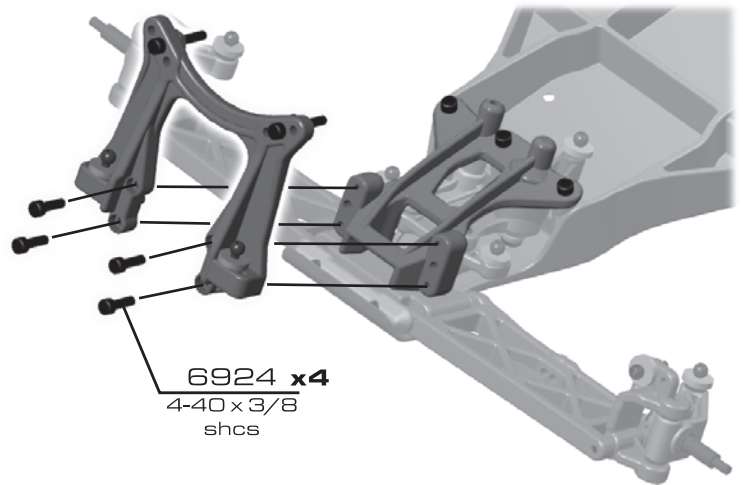

6924 x4  
4-40 x 3/8  
shcs

**:: Front Turnbuckles T4.1**

**B6**  
STEP 7



\* Orient the notch to the left throughout the car. It indicates which end has the left hand threads.

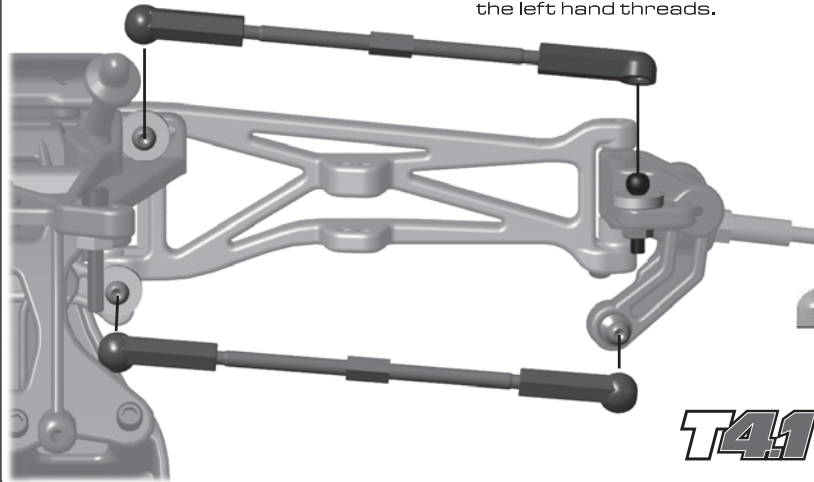

**T4.1**

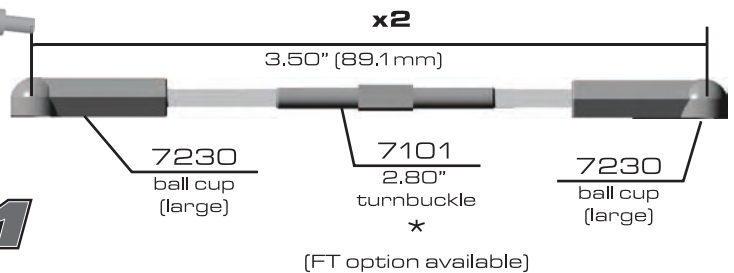
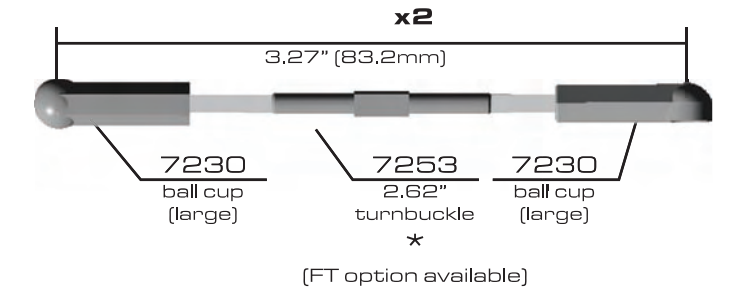

**:: Front Turnbuckles B4.1**

**B7**  
STEP 8



\* Orient the notch to the left throughout the car. It indicates which end has the left hand threads.

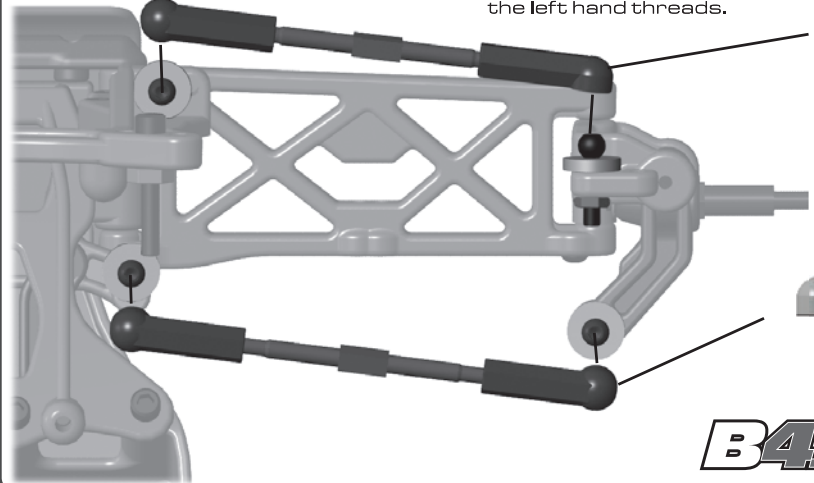

**B4.1**

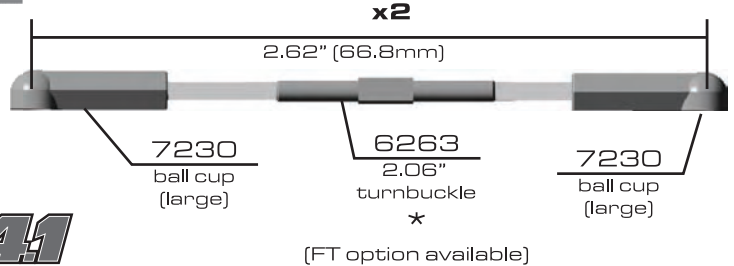
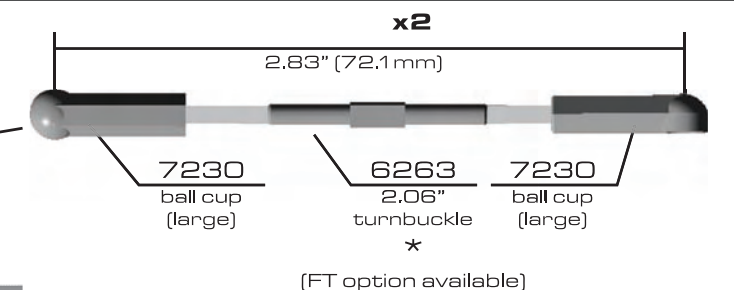

**:: Transmission**

**BAG C T41 & B41**

**C2**  
STEP 1

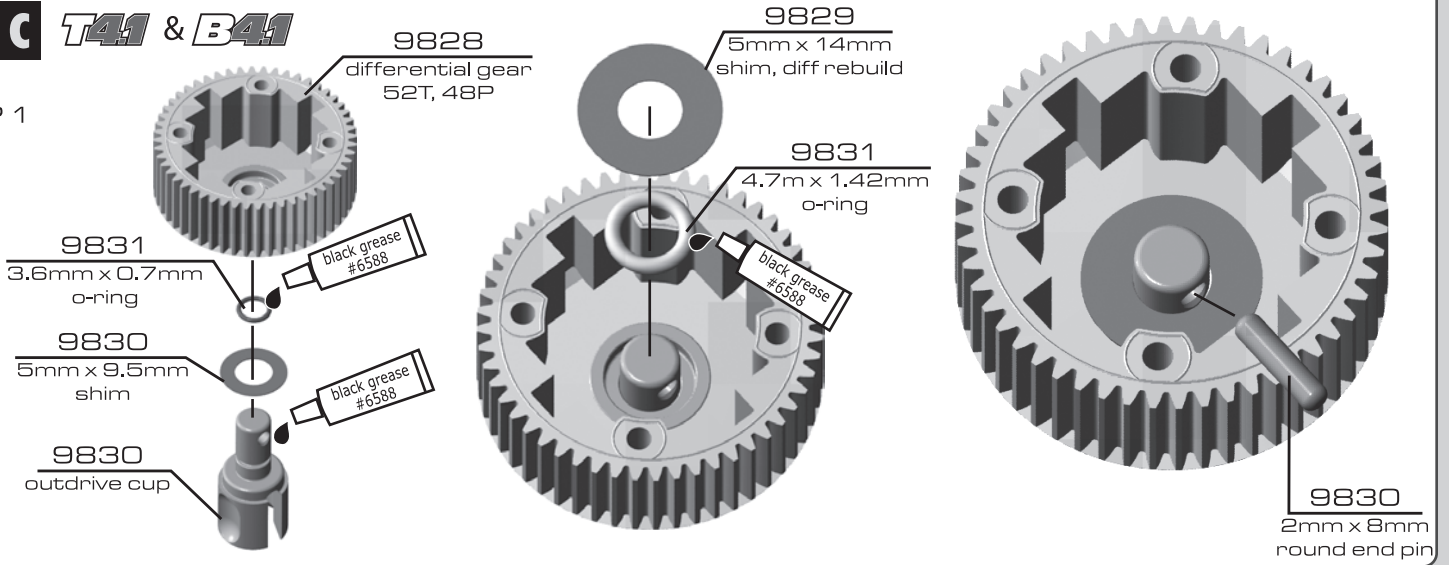

**:: Transmission (cont.)**

**C2/3 T41 & B41**  
STEP 2

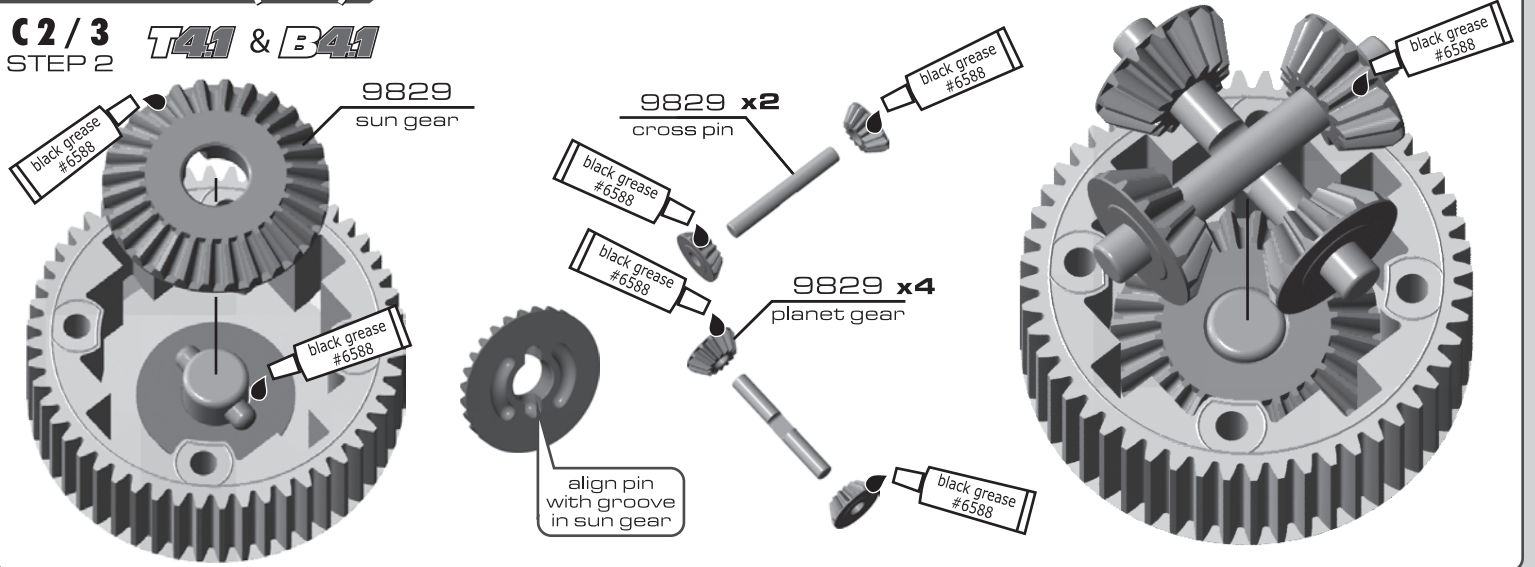

**:: Transmission (cont.)**

**C2 T41 & B41**  
STEP 3

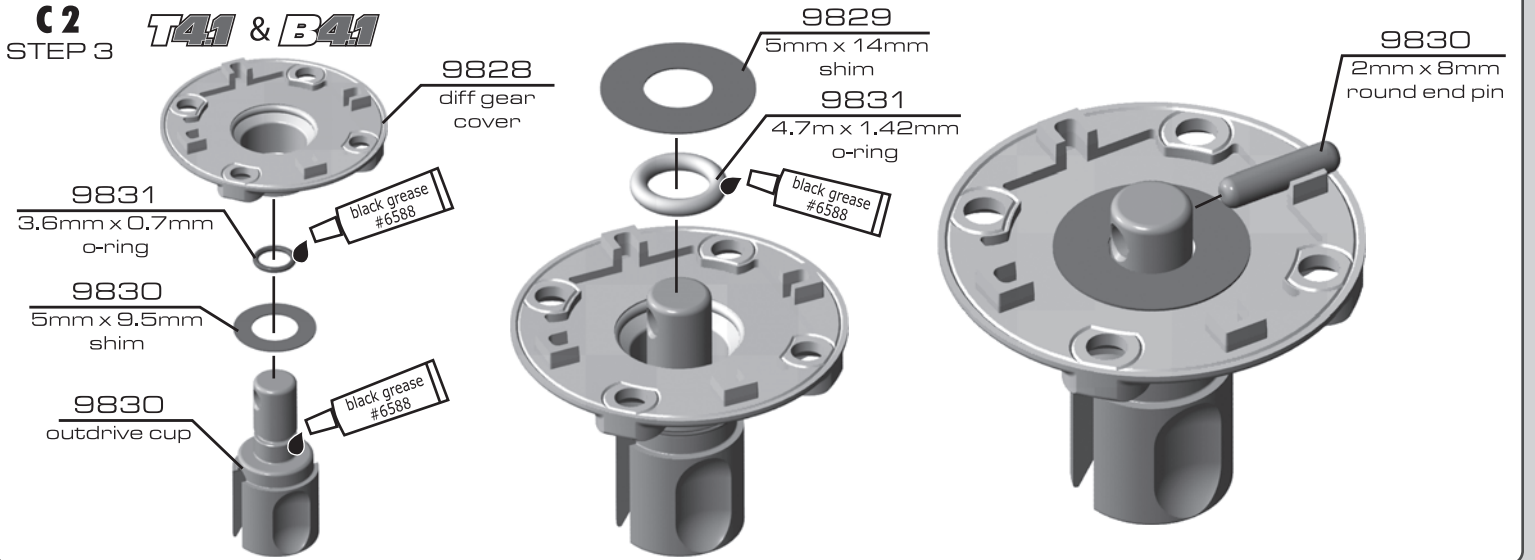

**:: Transmission (cont.)**

**C2 / 4 T41 & B41**  
STEP 4

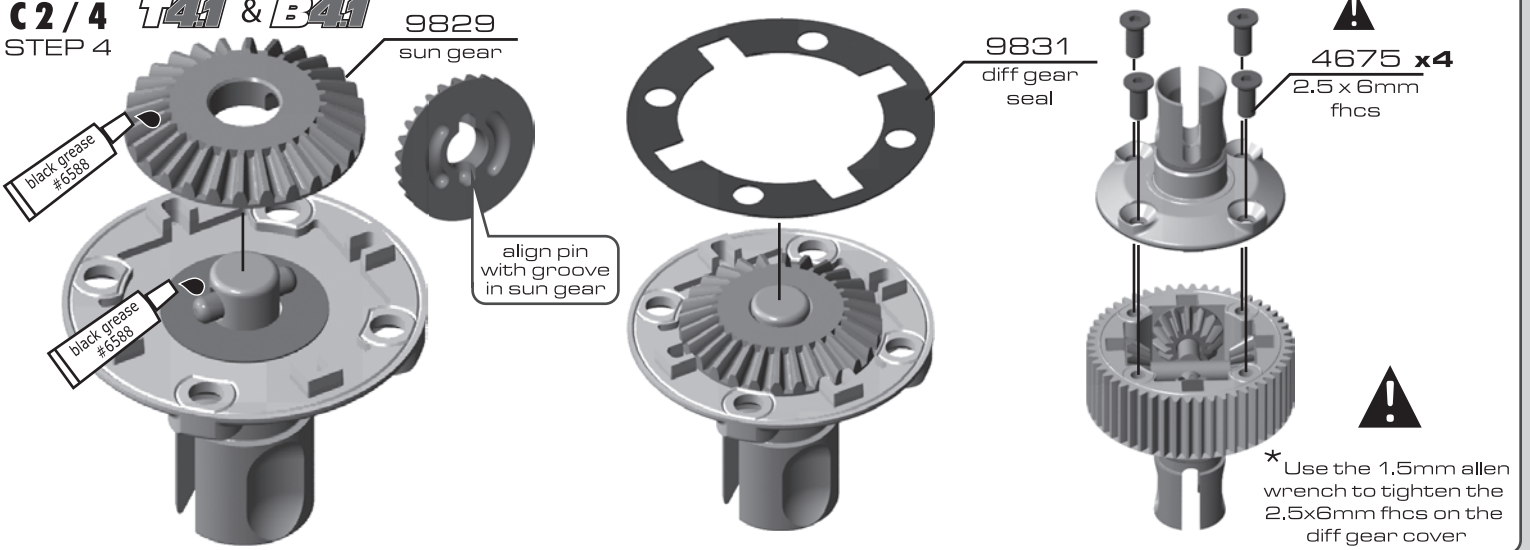

**:: Transmission (cont.)**

**C5 / 6 T41 & B41**  
STEP 5

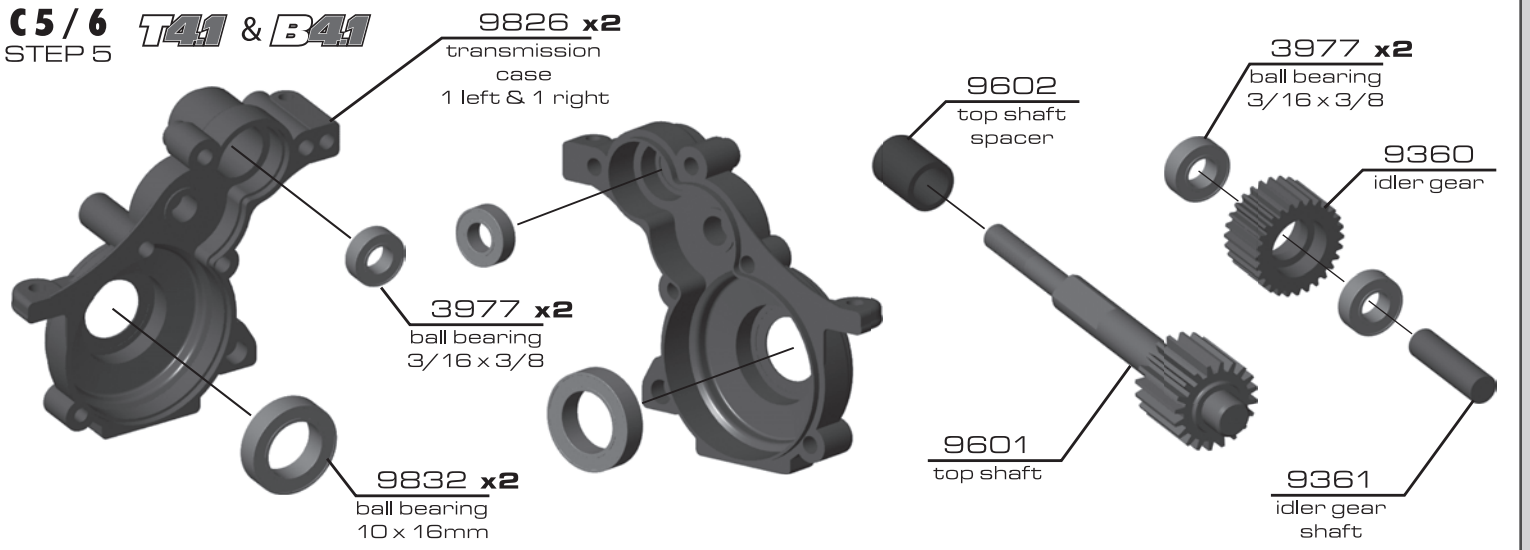

**:: Transmission (cont.)**

**C7 T41 & B41**  
STEP 6

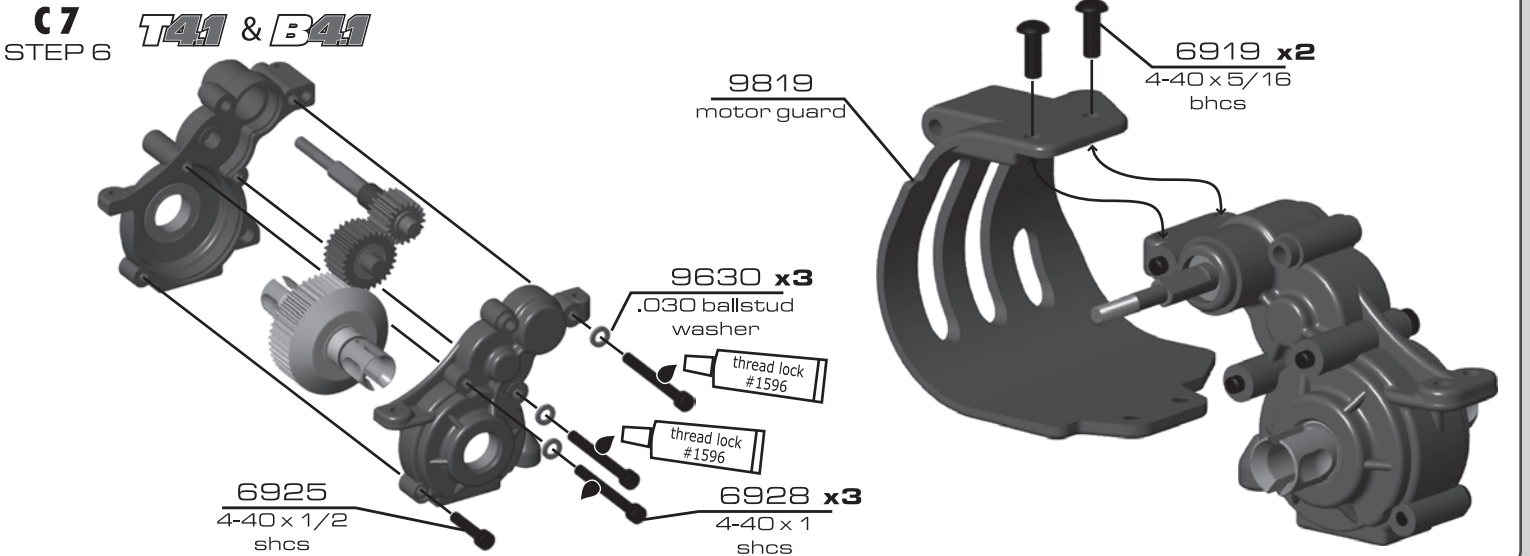



**:: Transmission (cont.)**

**C 8 / 9** **T4.1** & **B4.1**

STEP 7

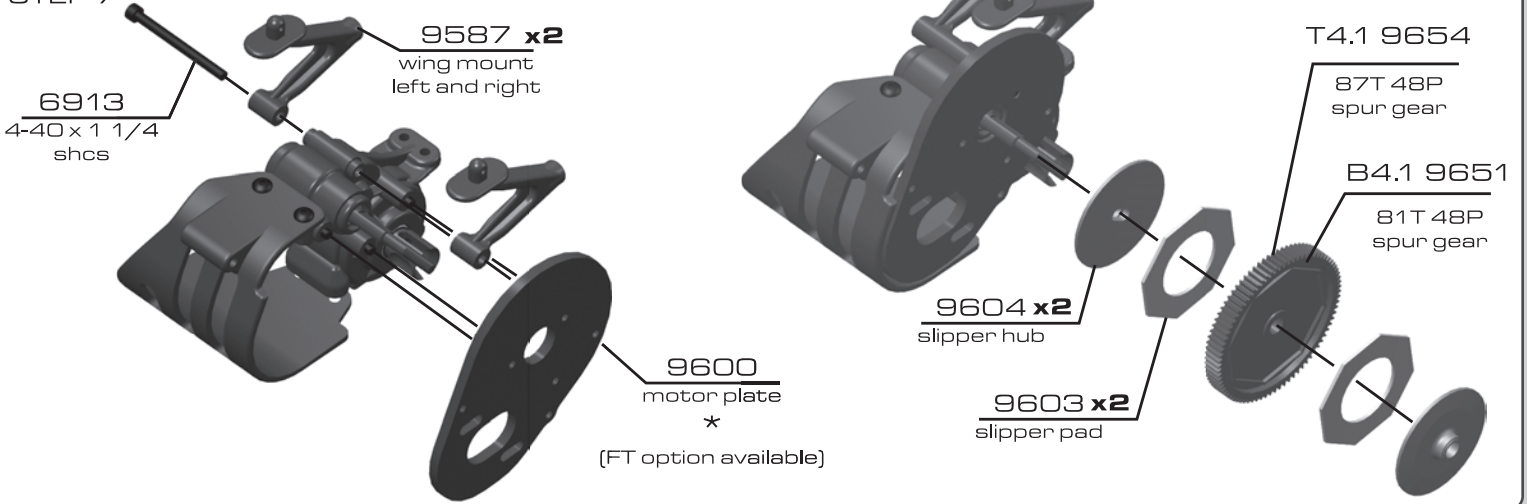

**:: Transmission (cont.)**

**C 10** **T4.1** & **B4.1**

STEP 8

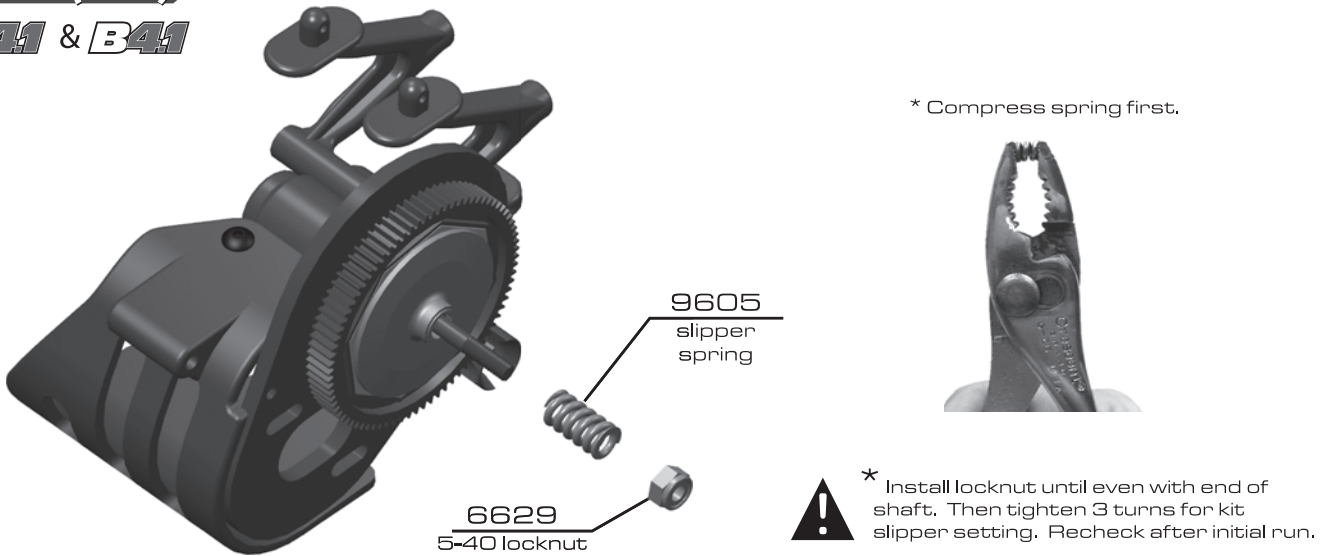

**:: Rear End**

**BAG D**

**D 2**

STEP 1

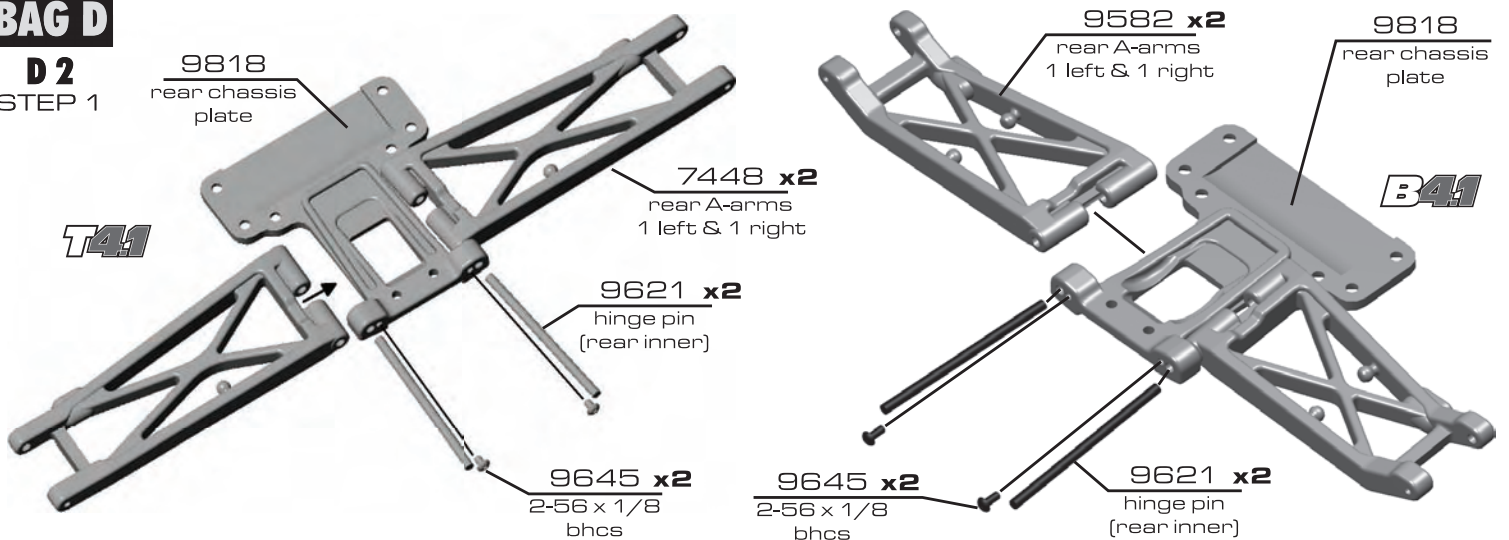

**:: Rear End (cont.)**

**D2**  
STEP 2 **T41** & **B41**

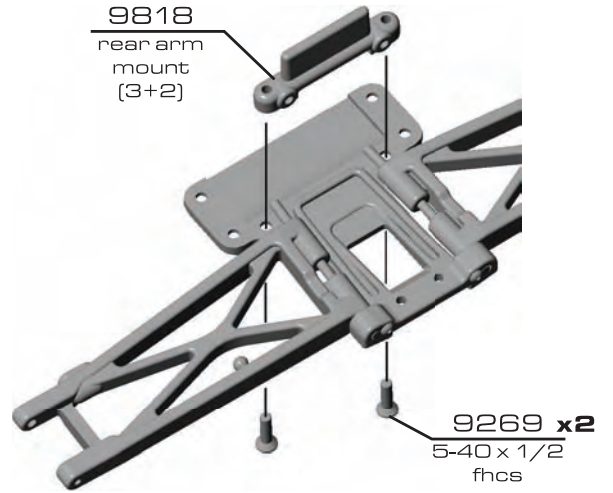
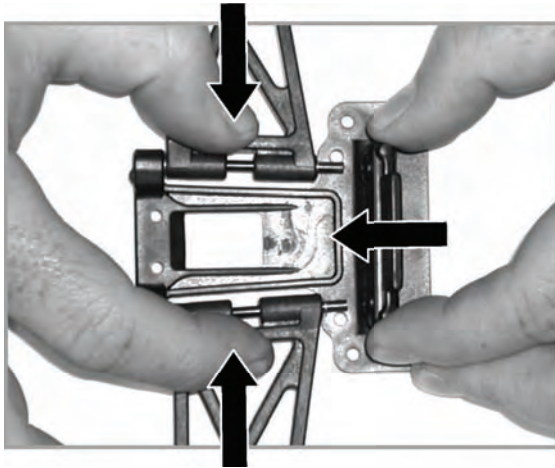

**:: Rear End (cont.)**

**D3**  
STEP 3 **T41** & **B41**

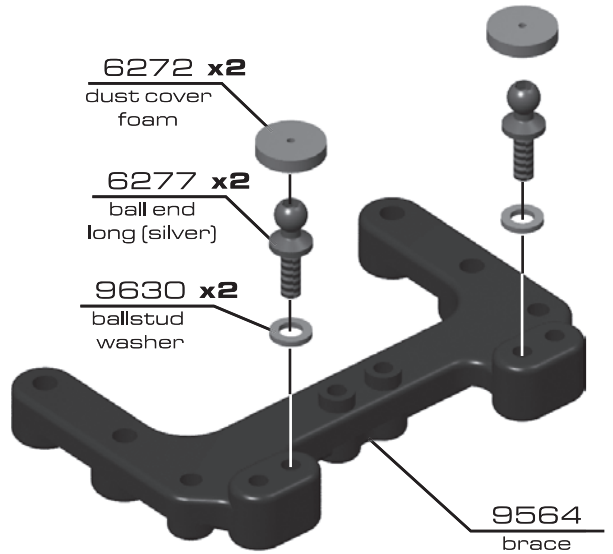
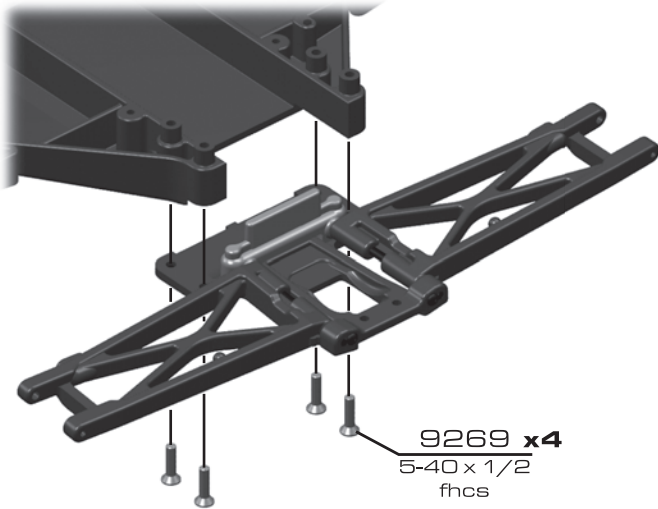

**:: Rear End (cont.)**

**D3**  
STEP 4 **T41** & **B41**

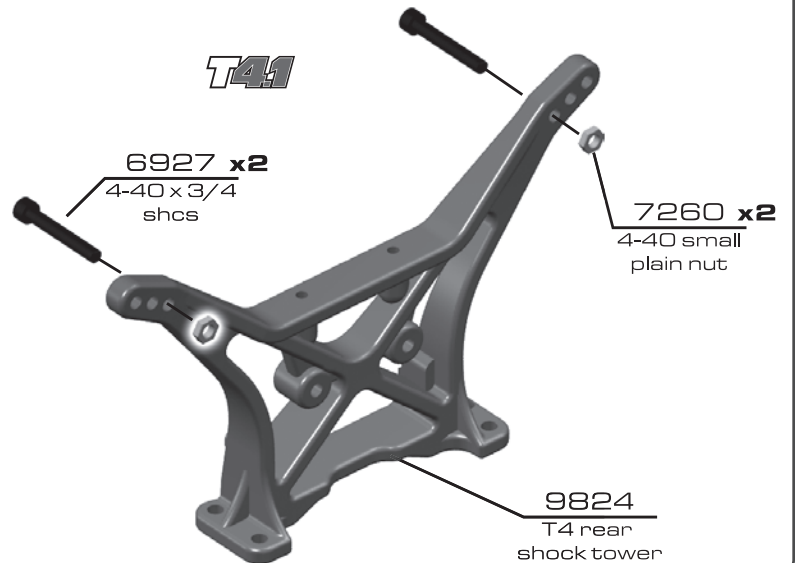
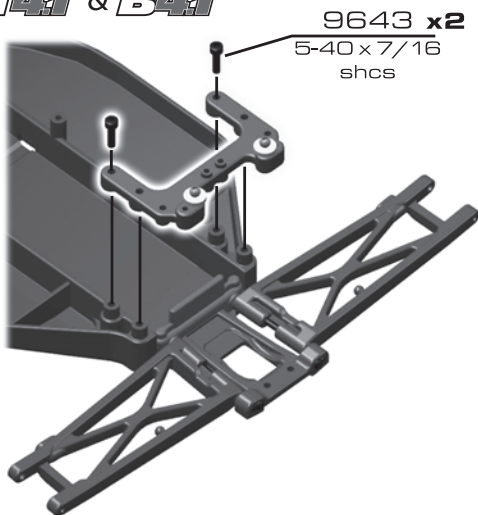

**:: Rear End (cont.)**

**D 4**  
STEP 5 **B41**

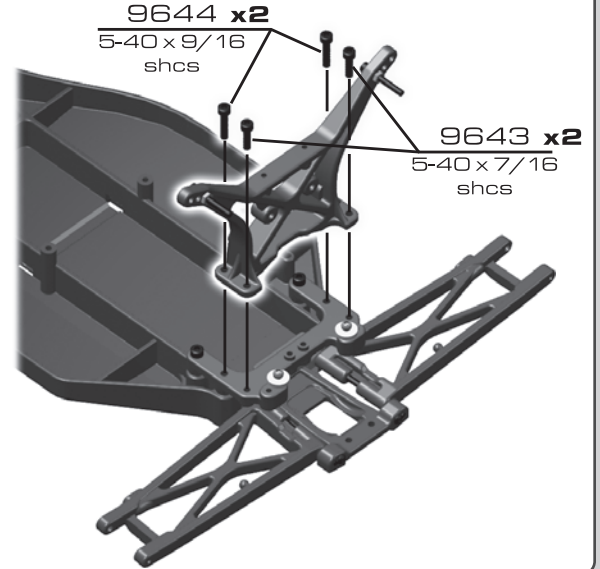
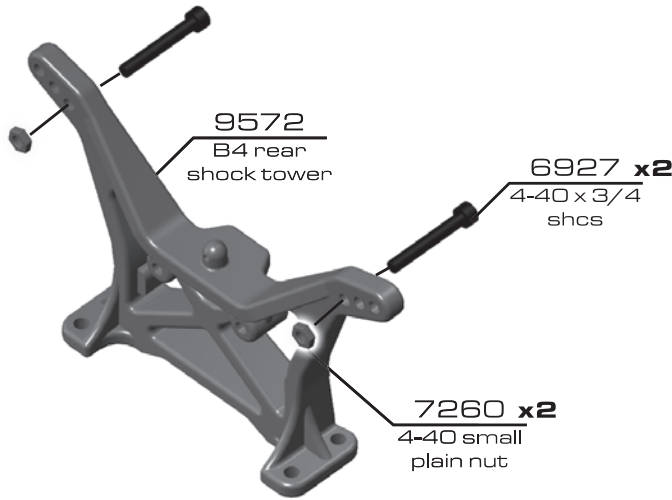

**:: Rear End (cont.)**

**D 5**  
STEP 6 **T41 & B41**

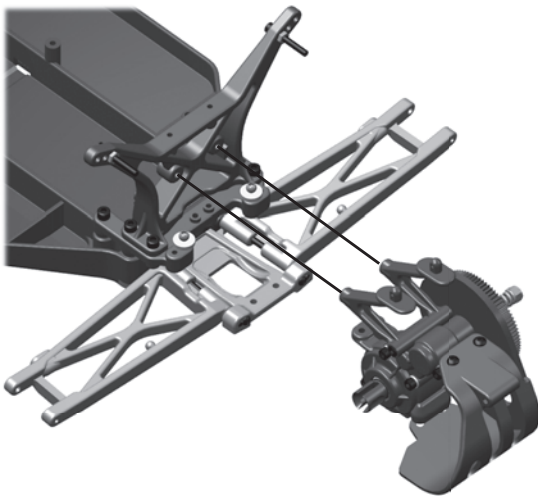

6915 x2  
4-40 x 5/8  
fhcs

6924 x2  
4-40 x 3/8  
shcs

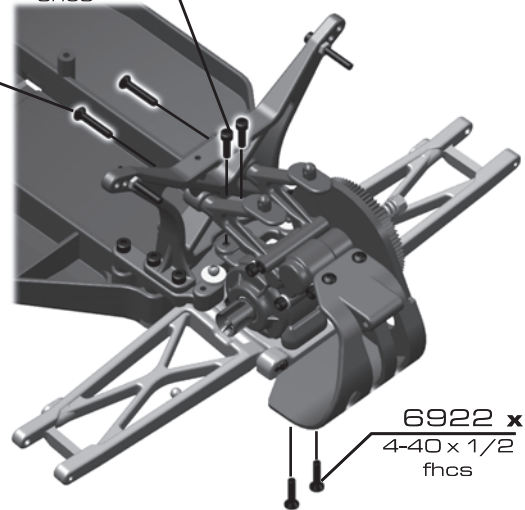

6922 x2  
4-40 x 1/2  
fhcs

**:: Rear Hubs**

**BAG E** **T41 & B41**

**E 2**  
STEP 1

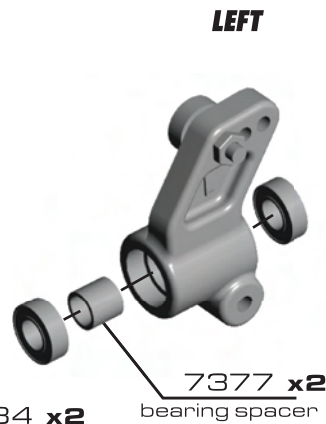
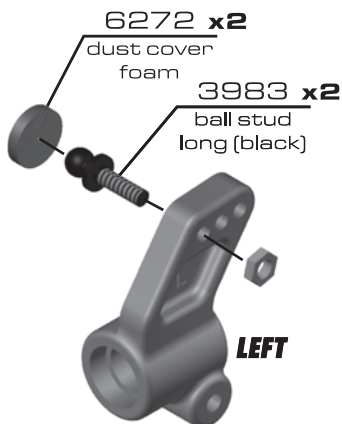

**:: Rear Hubs (cont.)**

**E3/4/5** **T4.1**  
STEP 2

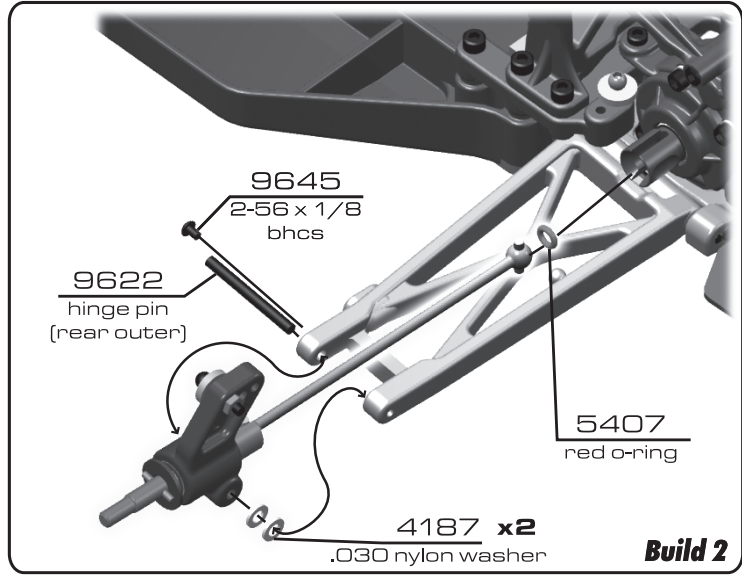
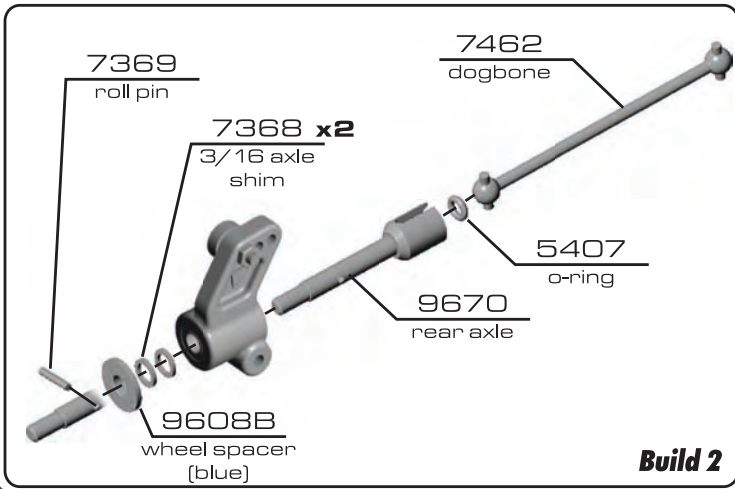

**:: Rear Hubs (cont.)**

**E3/4/5** **B4.1**  
STEP 3

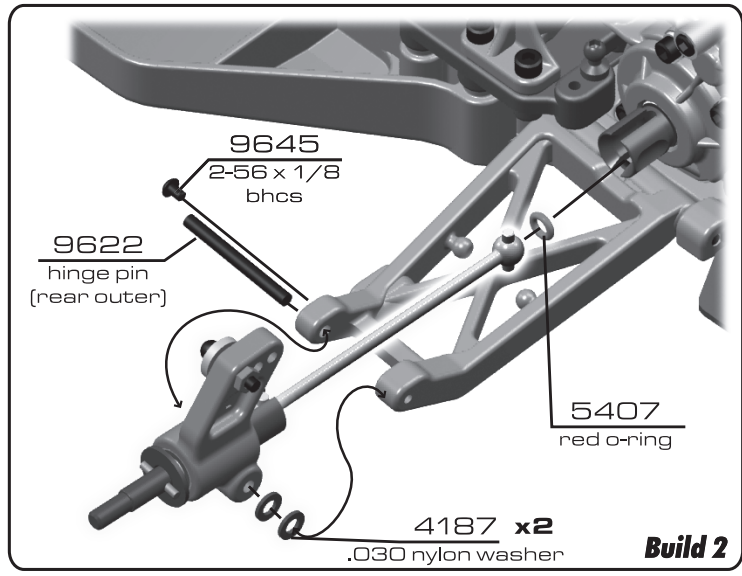
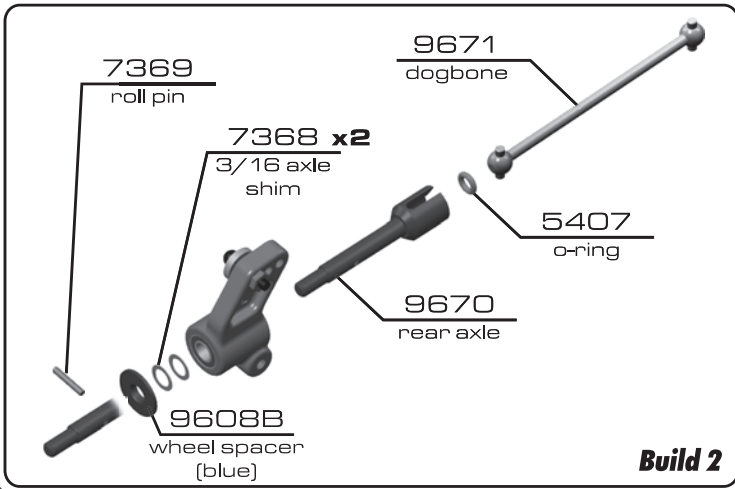

**:: Rear Camber Turnbuckle T4.1**

**E6** **T4.1**  
STEP 4



\* Orient the notch to the left throughout the car. It indicates which end has the left hand threads.

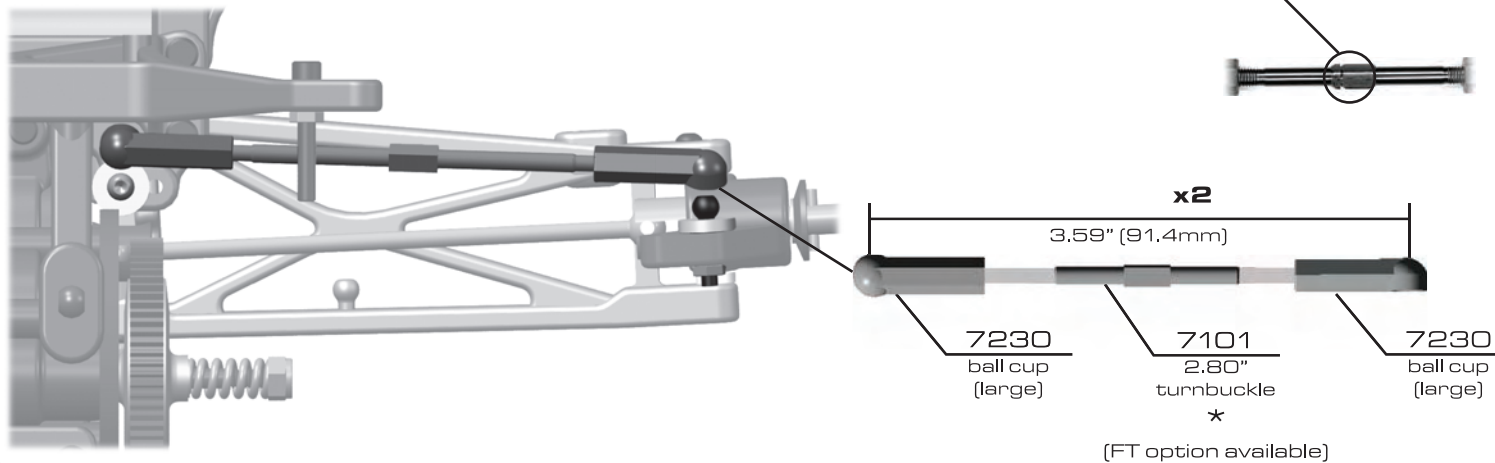

**:: Rear Camber Turnbuckle B4.1 (cont.)**

**E6**  
STEP 5 **B4.1**

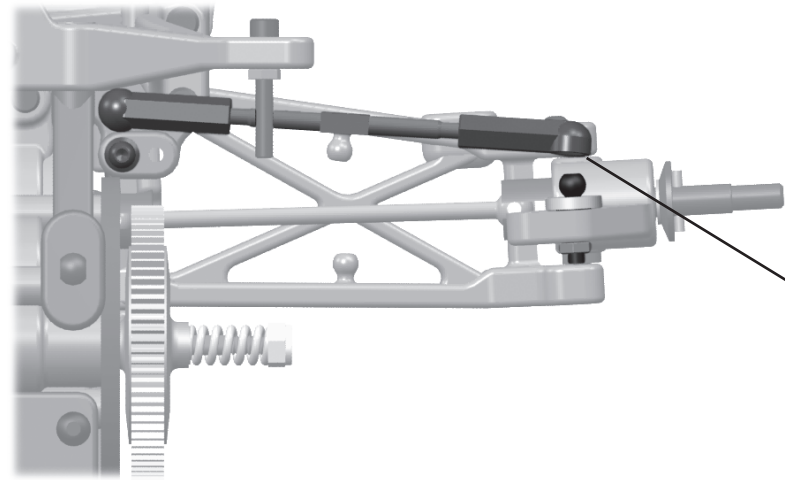

\* Orient the notch to the left throughout the car. It indicates which end has the left hand threads.

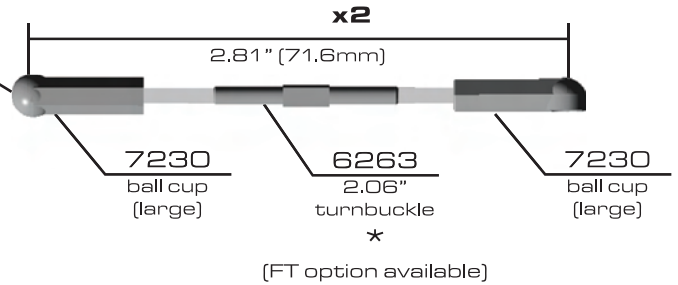

**:: Shocks**

**BAG F** **T4.1 & B4.1**

**F2**  
STEP 1

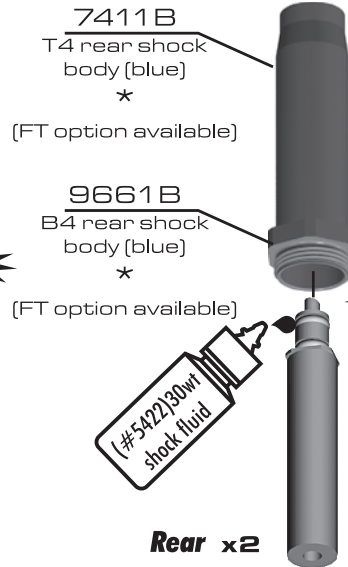
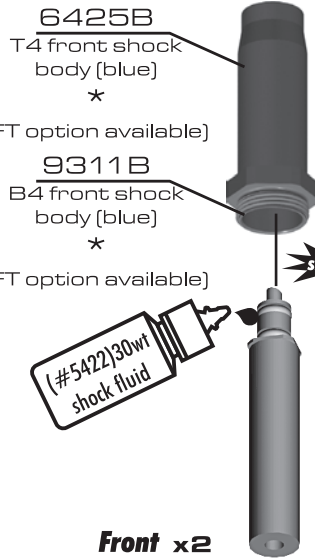
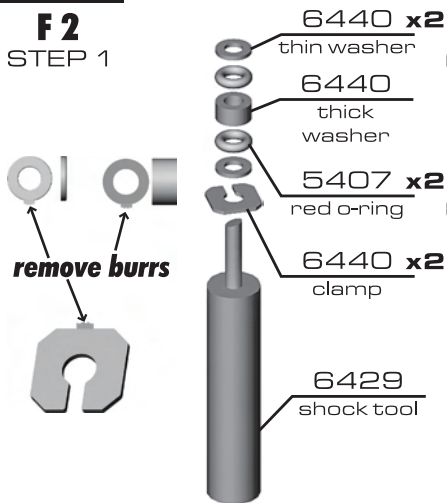

\* Place on table and push down hard until clamp snaps into place

**:: Shocks (cont.)**

**F2 / 3**  
STEP 2 **T4.1 & B4.1**

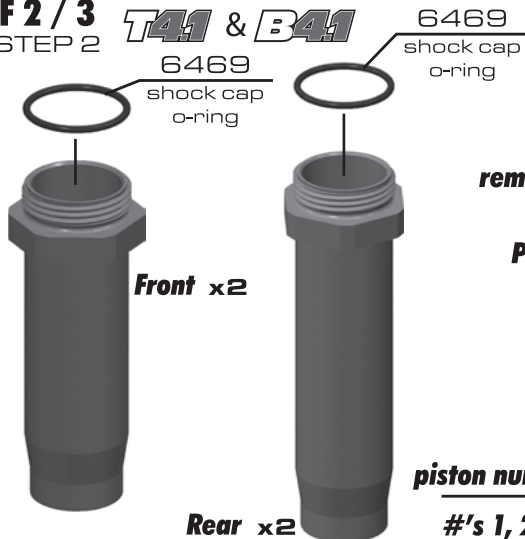

**T4.1 Front X2**

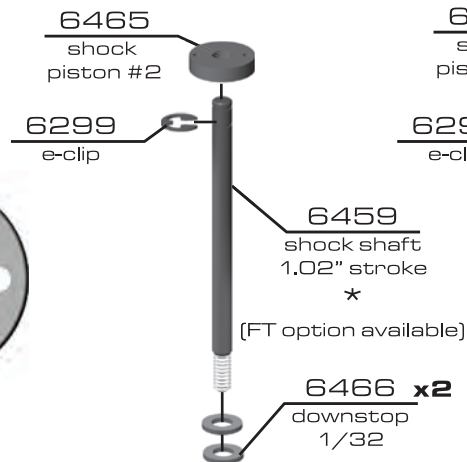

**B4.1 Front X2**

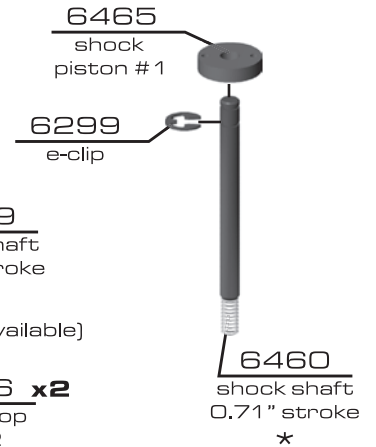

(FT option available)

**:: Shocks (cont.)**

**F3**  
STEP 3 **T4.1** & **B4.1**

**T4.1 Front X2**  
**B4.1 Front X2**

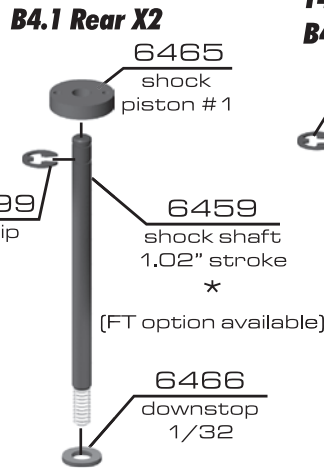
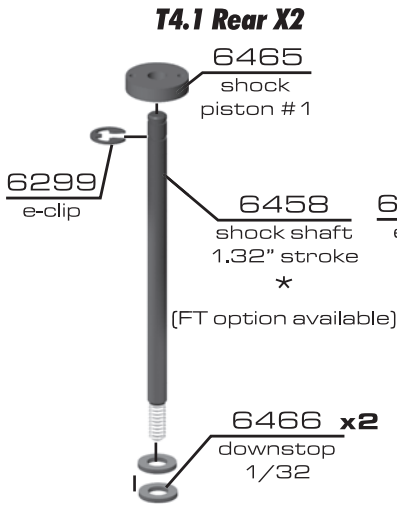

**T4.1 Rear X2**  
**B4.1 Rear X2**

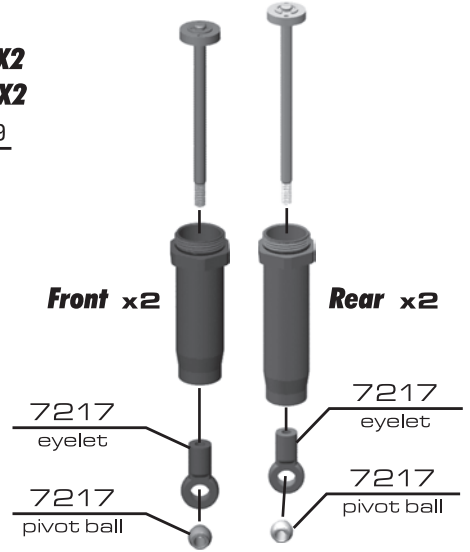

**:: Shocks (cont.)**

STEP 4 **T4.1** & **B4.1**

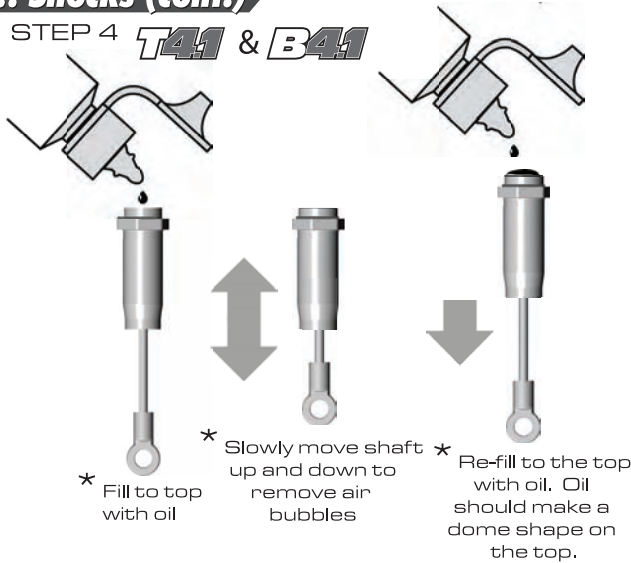

6428 x4 shock cap (molded)

**Shock Bleeding Steps:**

1. Slowly compress the shaft.
2. If there is pressure at the top of the stroke, there is too much oil or air. You must bleed it out.
3. Slowly pull shaft out.
4. Unscrew the cap 3/4 turn and tilt the shock at a slight angle.
5. Slowly compress the shaft to push out excess oil and air. You should see bubbles coming out from under the cap.
6. With the shaft compressed, tighten the cap and re-check for pressure at the top of the stroke. If there is still pressure, repeat steps 3-5.

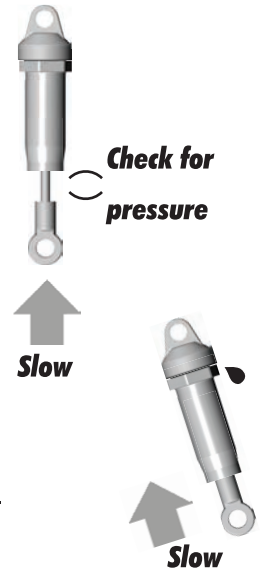

**:: Shocks (cont.)**

**F4 / 5**  
STEP 5 **T4.1** & **B4.1**

**Front x2**

**Rear x2**

**Front x2**

**Rear x2**

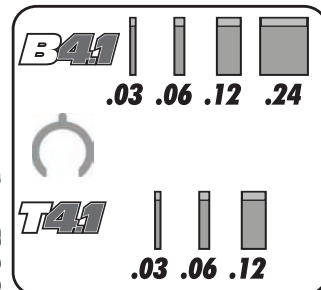
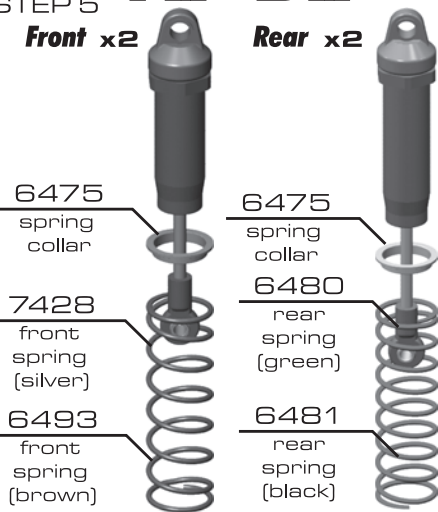

8846 preload spacers

**Front x2**

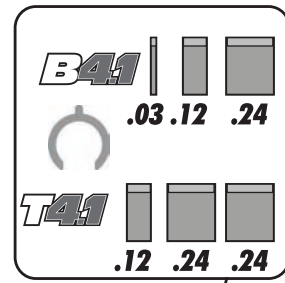
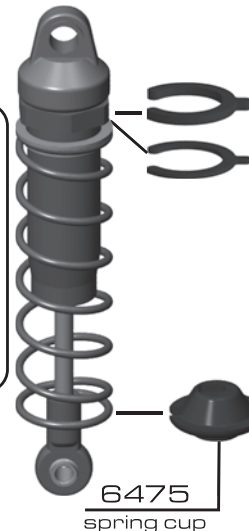

8846 preload spacers

6475 spring cup

**Rear x2**

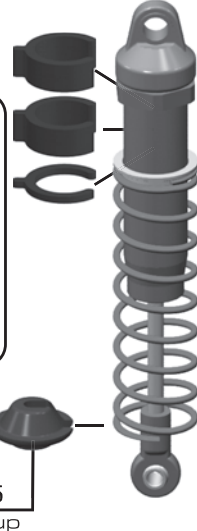

**:: Shocks (cont.)**

**F6**  
STEP 6

**T41**

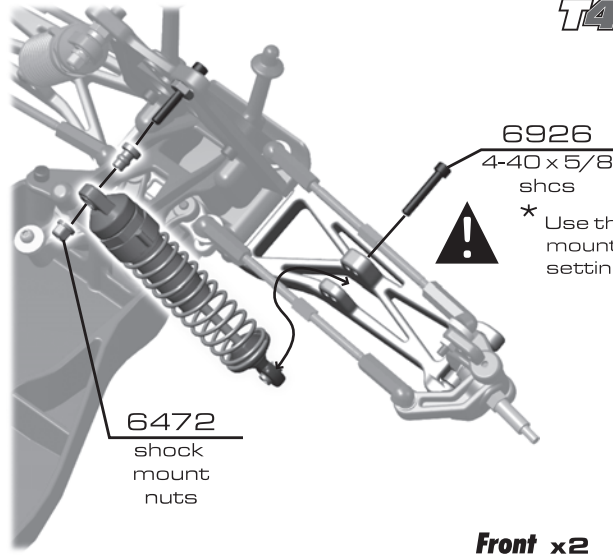

6926  
4-40 x 5/8  
shcs

\* Use the outside shock mount hole for stock settings.

6472  
shock mount nuts

**Front x2**

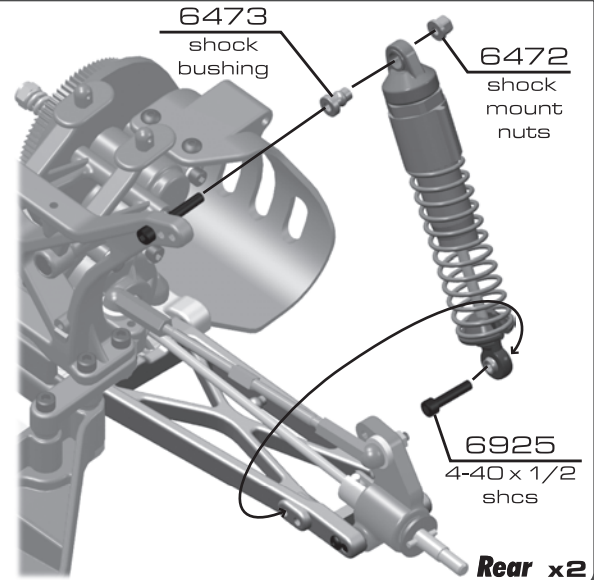

6473  
shock bushing

6472  
shock mount nuts

6925  
4-40 x 1/2  
shcs

**Rear x2**

**:: Shocks (cont.)**

**F6**  
STEP 7

**B41**

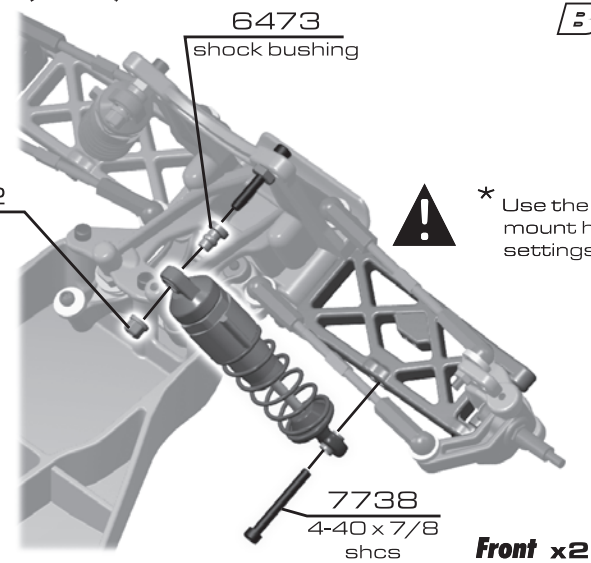

6473  
shock bushing

6472  
shock mount nuts

\* Use the outside shock mount hole for stock settings.

7738  
4-40 x 7/8  
shcs

**Front x2**

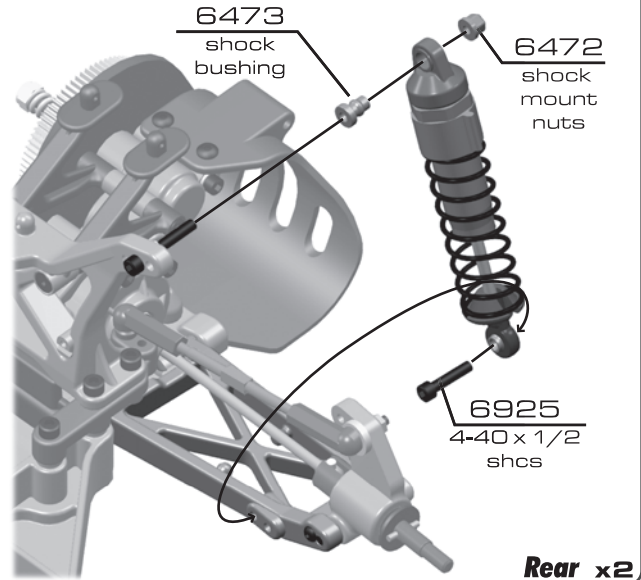

6473  
shock bushing

6472  
shock mount nuts

6925  
4-40 x 1/2  
shcs

**Rear x2**

**:: Steering Servo**

**BAG G T41 & B41**

**G 2 / 3**  
STEP 1

29132  
AE SHV  
1504 MG  
servo

7337 x4  
gold washer

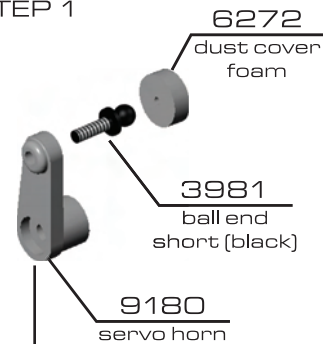

6272  
dust cover foam

3981  
ball end short (black)

9180  
servo horn

\*Screw supplied with servo

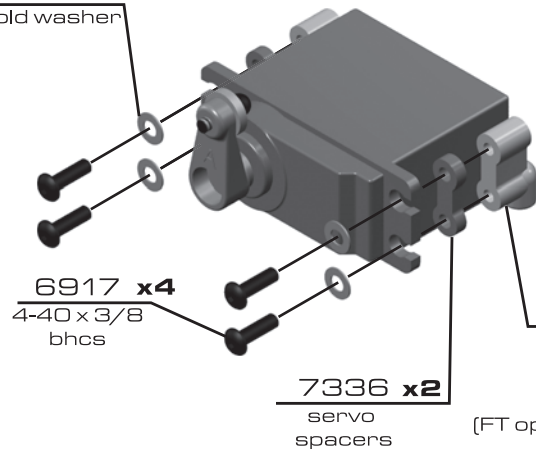

6917 x4  
4-40 x 3/8  
bhcs

7336 x2  
servo mount  
\*

(FT option available)

7336 x2  
servo spacers

\* See page 24 for correct servo horn on the servo chart

\* See page 24 for correct servo spacing on the servo chart

**:: Steering Servo (cont.)**

**G4**  
STEP 2 **T4.1 & B4.1**

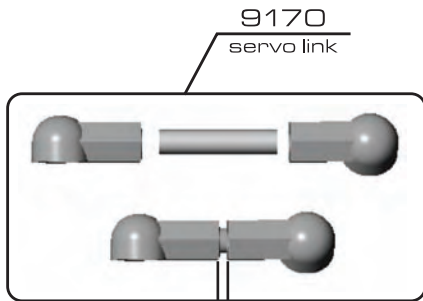

\*Leave a 1/16" gap

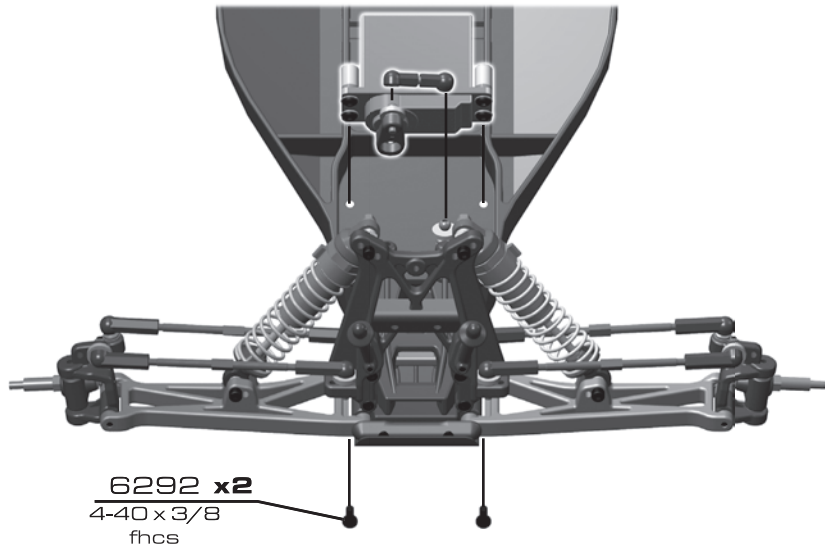

**6292 x2**  
4-40 x 3/8  
fhcs

**:: Motor / Gear Cover**

**G5/6**  
STEP 3 **T4.1 & B4.1**

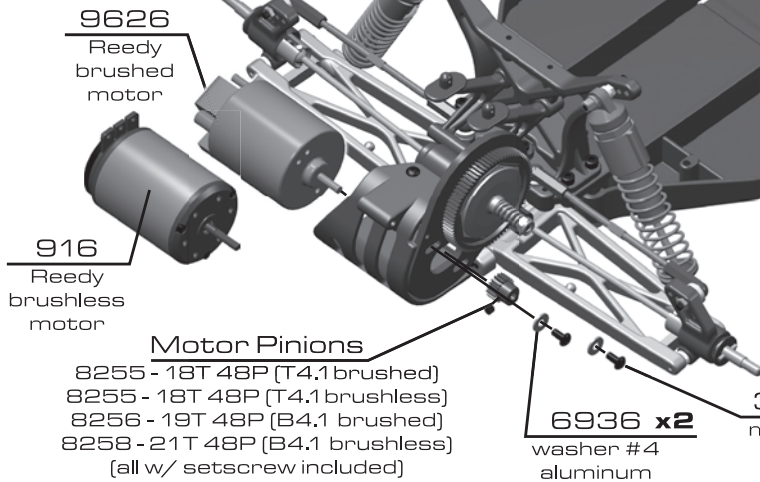

**9626**  
Reedy  
brushed  
motor

**916**  
Reedy  
brushless  
motor

**Motor Pinions**

- 8255 - 18T 48P (T4.1 brushed)
- 8255 - 18T 48P (T4.1 brushless)
- 8256 - 19T 48P (B4.1 brushed)
- 8258 - 21T 48P (B4.1 brushless)
- (all w/ setscrew included)

**6936 x2**  
washer #4  
aluminum

**31531 x2**  
m3x6mm  
bhcs

\* See page 20 for  
gear mesh setting  
instructions

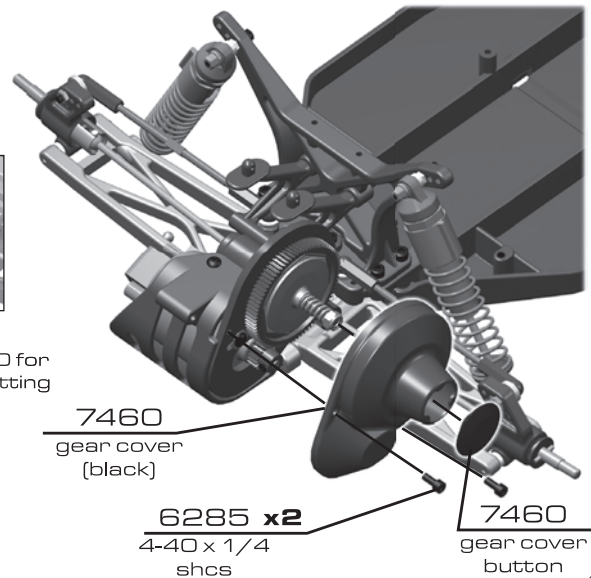

**7460**  
gear cover  
(black)

**6285 x2**  
4-40 x 1/4  
shcs

**7460**  
gear cover  
button

**:: Electronics / Battery Strap**

**G7/8**  
STEP 4 **T4.1 & B4.1**

**3862**  
5-40 x 1/8  
set screw

**6338**  
antenna tube  
and cap

**29222**  
XP3-SS  
receiver

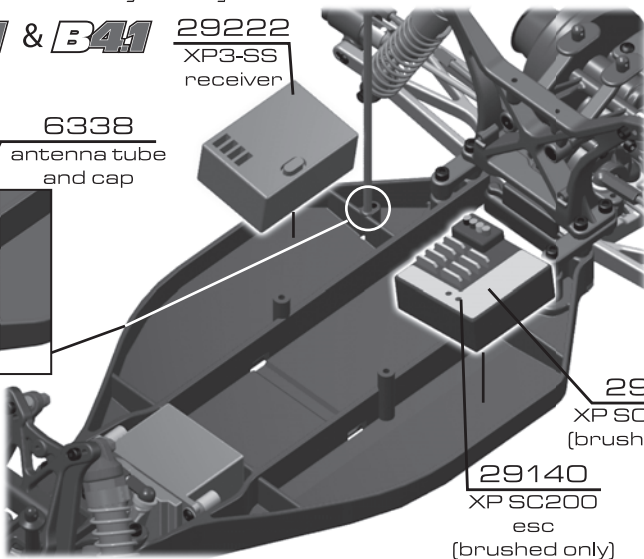
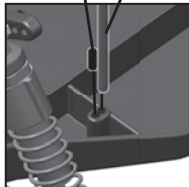

**29141**  
XP SC450-BL  
(brushless only)

**29140**  
XP SC200  
esc  
(brushed only)

\* Use servo tape to secure  
your speed controller and  
receiver into the chassis

**9793 x2**  
thumb knob  
(B4.1)

**7473 x2**  
4-40 x 1/2  
set screw  
(T4.1)

**9793 x2**  
4-40 x 1/2  
set screw  
(B4.1)

**7473 x2**  
thumb knob  
(T4.1)

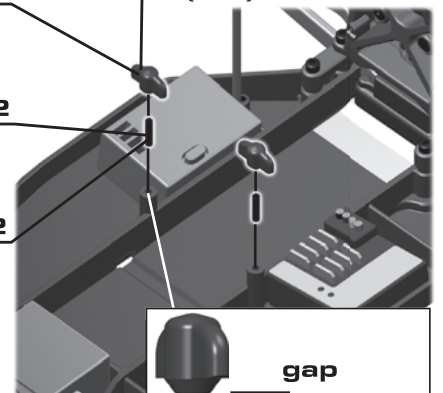

gap

\* leave a  
2.5mm gap



**:: Battery Strap (cont.)**

**G7/8** **T4.1 & B4.1**  
STEP 5

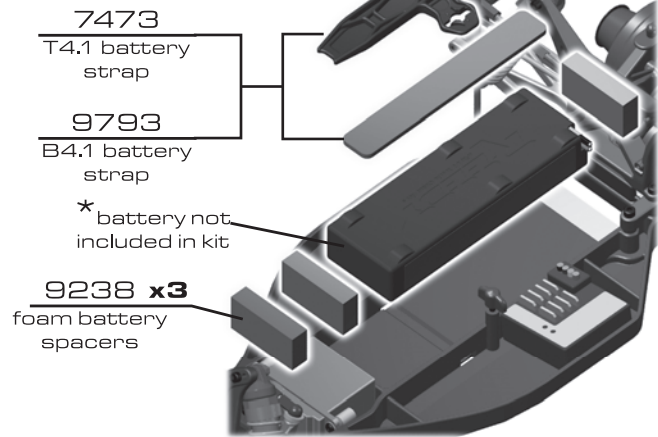

**!**  
\* Use foam pad as needed to secure your battery.

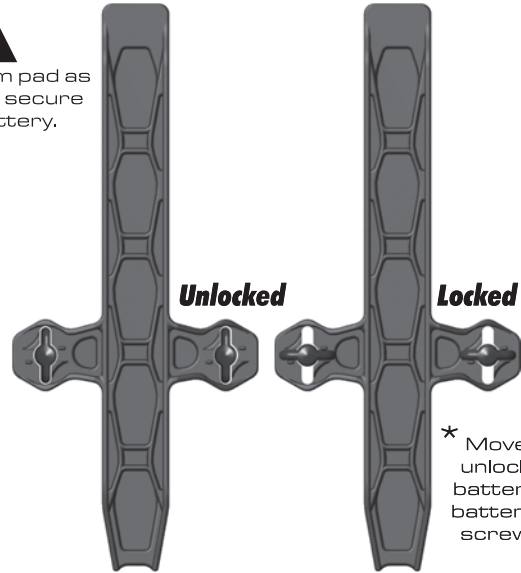

**!**  
\* Move thumb screws to the unlocked position and lift the battery strap to remove your battery pack. Lock the thumb screws after you install your battery pack.

**:: Wheels and Tires T4.1**

**BAG H** **T4.1**

**H1**  
STEP 1



**!**  
\* Use cyanoacrylate glue AE Pt # 1597 to glue your tires to the wheels.

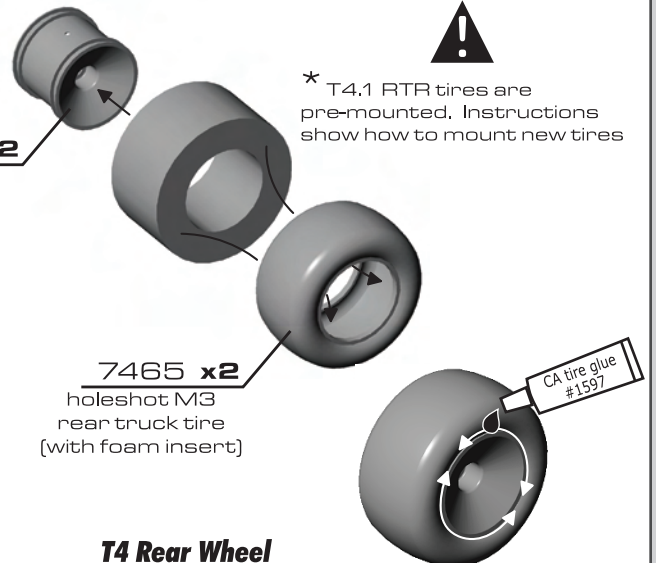

**!**  
\* T4.1 RTR tires are pre-mounted. Instructions show how to mount new tires

**T4 Front Wheel**

**T4 Rear Wheel**

**:: Wheels and Tires B4.1**

**H1** **B4.1**  
STEP 1



**!**  
\* Use cyanoacrylate glue AE Pt # 1597 to glue your tires to the wheels.

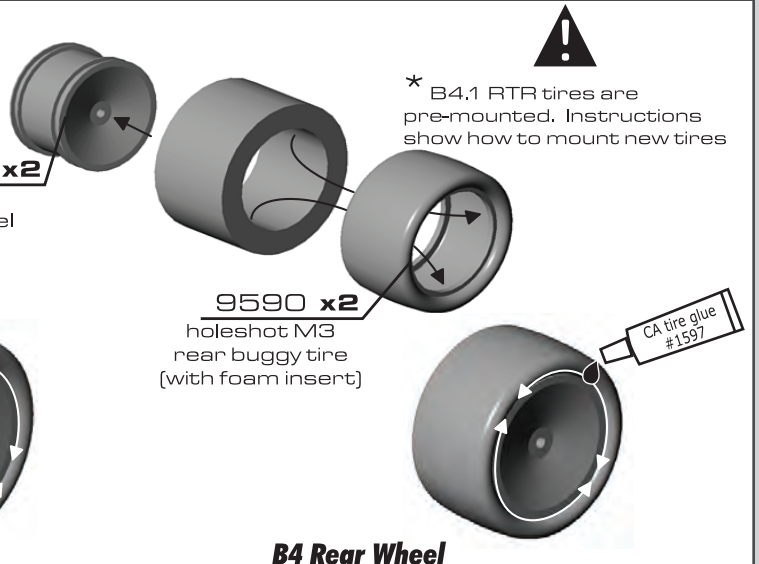

**!**  
\* B4.1 RTR tires are pre-mounted. Instructions show how to mount new tires

**B4 Front Wheel**

**B4 Rear Wheel**

**:: Wheels and Tires T4.1 (cont.)**

**H 2**  
STEP 2 **T4.1**

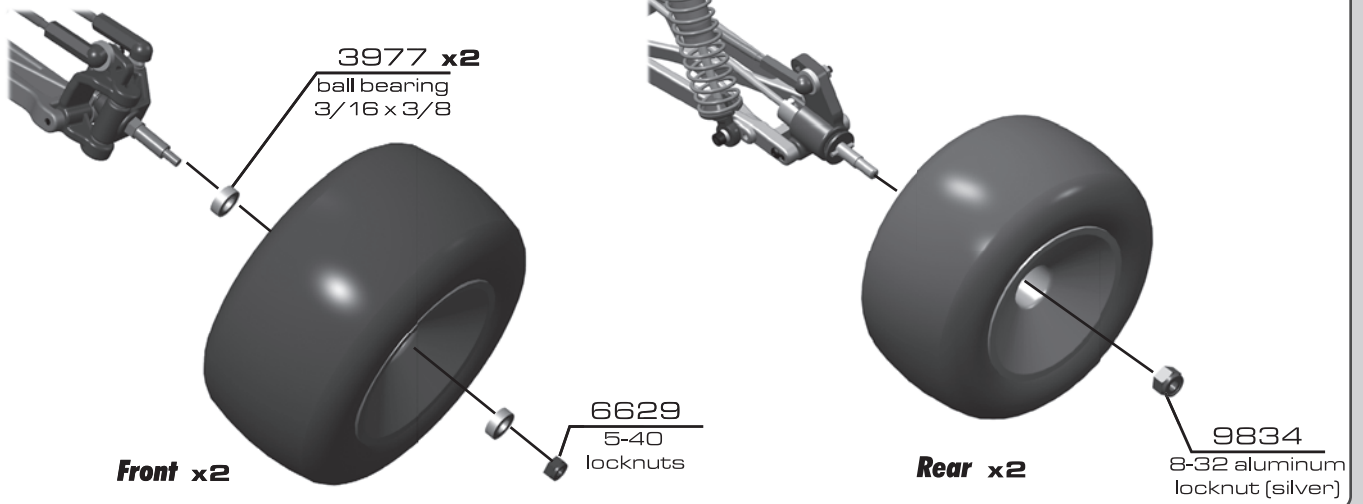

**:: Wheels and Tires B4.1 (cont.)**

**H 2**  
STEP 3 **B4.1**

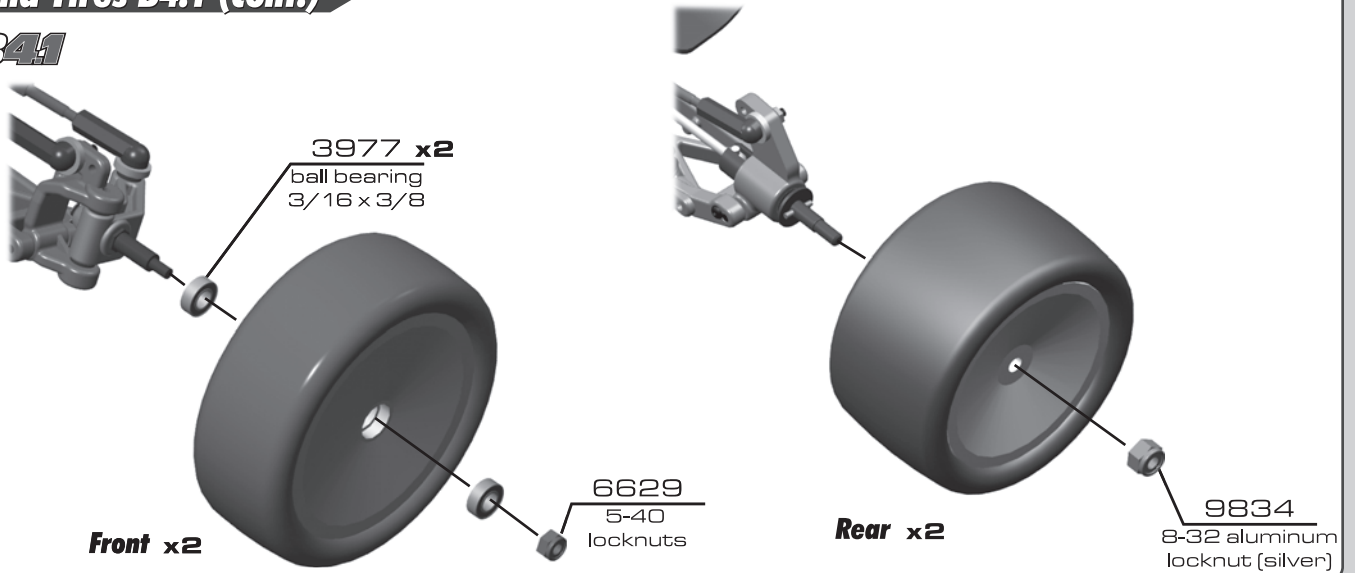

**:: Wing Adjustments**

**H 2**  
STEP 4 **T4.1**

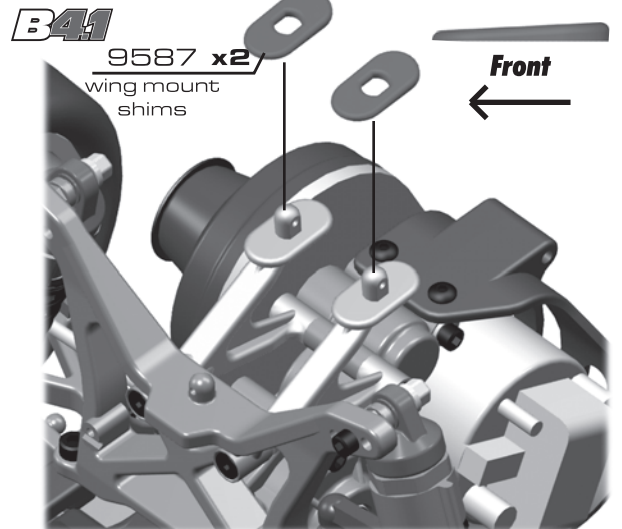
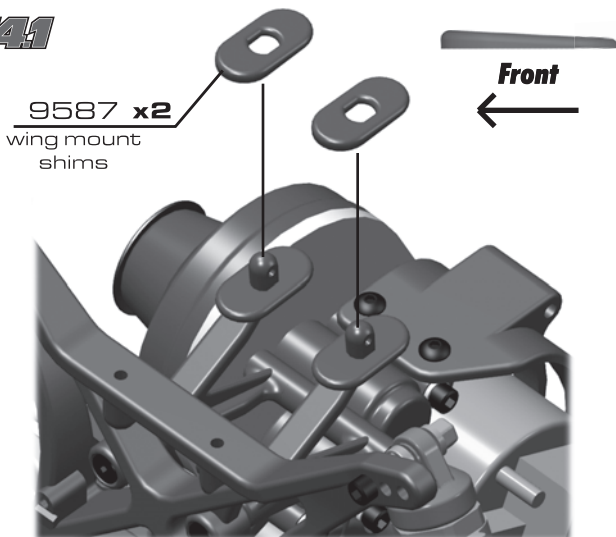

## :: Bodies and Wings

### H 2 STEP 4 T41 & B41

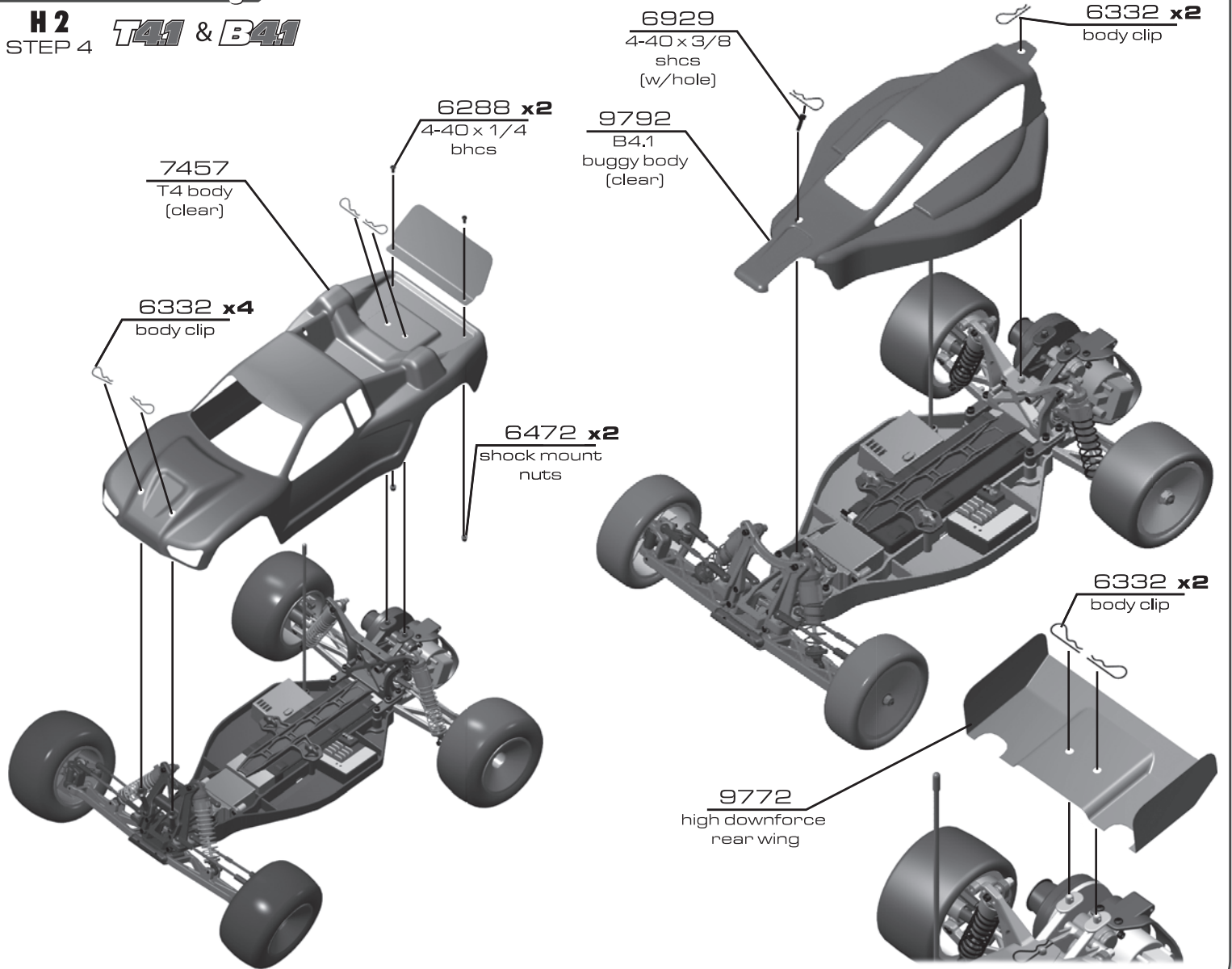

## :: Adjustments / Tips

Use the following steps to make the final adjustments on your truck.

1. Turn the transmitter on.
2. Make sure the motor is disconnected.
3. Connect your battery pack and turn the power switch on.
4. Move the steering control on the transmitter to the right and left. Do the wheels move in the correct direction? If not, you must reverse the steering servo direction on your transmitter (see transmitter manual).
5. Adjust your steering trim (see radio manual) until the steering rack is centered under the top plate. Then, using the two steering turnbuckles, adjust the front wheels so they are pointing straight ahead.
6. Adjust the ESC (electronic speed control) according to the speed control manufacturer's instructions. **Some manufacturers have the motor connected during adjustment and some do not.** Now turn the power switch off.
7. Connect the motor. Place your car on a block or car stand so that all four wheels are elevated. Turn the power switch on again. Check the throttle, brake, and steering settings you have made and then turn the power switch back off.
8. Remember this! The transmitter is always the **FIRST TO BE TURNED ON** and **THE LAST TO BE TURNED OFF.**

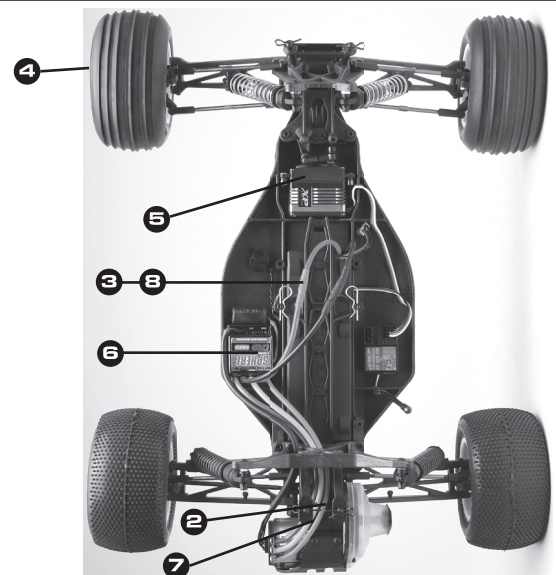

## :: Adjustments / Tips

### Motor Gearing:

Proper motor gearing will result in maximum performance and run time while reducing the chance of overheating and premature motor failure. The gear ratio chart lists recommended starting gear ratios for the most widely used motor types. Gear ratios will vary depending upon track conditions, driving style, and personal preference. Generally, you should not increase the pinion gear size more than one tooth greater than the starting size.

The gear ratios below are basic guidelines only. Please see the motor manufacturer's instructions for the correct gear ratio for the motor and battery you are using.

MOTOR	B4.1			T4.1		
	Pinion	Spur	FDR	Pinion	Spur	FDR
27T Stock Motor	23	81	9,16:1	20	87	11,31:1
19T Super Stock Motor	22	81	9,57:1	19	87	11,91:1
Radon 17T Motor	19	81	11,08:1	18	87	12,57:1
17.5 Brushless Motor	33	75	5,91:1	30	75	6,50:1
13.5 Brushless Motor	28	75	6,96:1	26	78	7,80:1
10.5 Brushless Motor	25	81	8,42:1	22	87	10,28:1
9.5 Brushless Motor	24	81	8,76:1	21	87	10,77:1
8.5 Brushless Motor	23	81	9,16:1	20	87	11,31:1
7.5 Brushless Motor	22	81	9,57:1	19	87	11,91:1
6.5 Brushless Motor	21	81	10,03:1	18	87	12,57:1
3300kV Brushless Motor	21	81	10,03:1	18	87	12,57:1
3900kV Brushless Motor	21	81	10,03:1	18	87	12,57:1
4900kV Brushless Motor	19	81	11,08:1	17	87	13,31:1
6100kV Brushless Motor	18	81	11,70:1	16	87	14,14:1

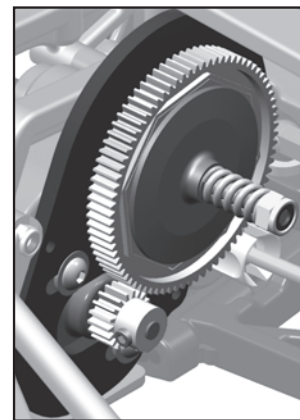

### Set The Gear Mesh

You should be able to rock the spur gear back and forth in the teeth of the pinion gear without making the pinion gear move. If the spur gear mesh is tight, then loosen the #31531 screws and move the motor away, then try again. A gear mesh that is too tight or too loose will reduce power and damage the gear teeth.

## MAINTENANCE

### Check For Fit

Periodically check all moving suspension parts. Suspension components must be kept clean and move freely without binding to prevent poor and/or inconsistent handling.

### Motor Maintenance

Brushed motors require frequent maintenance to keep performance levels at their maximum. Between runs and after letting the motor cool completely, inspect the brushes to ensure that they are moving freely in their holders. Remove the springs and slide the brushes in and out of their holders checking for any resistance or rough spots. If found, remove the brush and carefully wipe it clean. Removing buildup will allow the brush to slide freely and create maximum contact with the commutator resulting in maximum power output.

After every 3-5 runs, remove the brushes from their holders and inspect the tips for wear or burning. If there is noticeable wear (less than 75% of the brush remaining), replace the brush with a new pair. If the tips become a burned blue color, the lubricant in the brush has been burned away and new brushes should be installed.

Occasionally, the motor should be cleaned with a soft brush to prevent dirt build-up around the brush hoods and bearings. After cleaning and after every few runs, add one drop of bearing oil to each bearing.

If using a brushless motor, please refer to the motor manufacturer's guidelines for proper maintenance.

### Slipper Clutch

The assembly instructions give you a base setting for your clutch. Turn the nut on the shaft so that the end of the top shaft is even with the outside of the nut. Tighten the nut 3 more turns. At the track, tighten or loosen the nut in 1/8 turn increments until you hear a faint slipping sound for 1-2 feet on takeoffs.

Another popular way to set the clutch is to hold both rear tires firmly in place and apply short bursts of throttle. If the clutch is properly set, the front tires should lift slightly up off the surface.

## :: Adjustments / Tips

### Front Camber Links

Changing the length of the camber link is considered a bigger step than adjusting the ball end height on the tower. Shortening the camber link (or lowering the ball end) will give the front end less roll and quicken steering response. Lengthening the camber link (or raising the ball end) will give the front more roll and slower steering response.

Longer camber links are typically used on high grip tracks and shorter links tend to work better on medium-grip loose tracks.

### Caster

Caster describes the angle of the kingpin as it leans toward the rear of the vehicle. Positive caster means the kingpin leans rearward at the top. The supplied 25° caster blocks (#7919) are recommended in most cases. For more corner entry steering and less exit steering, try the optional 30° blocks (#7922).

### Front Camber

Camber describes the angle at which the tire and wheel rides when looked at from the front. Negative camber means that the tire leans inward at the top.

A good starting camber setting is -1°. Use the included #1719 camber gauge to set your camber. Positive camber, where the top of the tire is leaning out, is not recommended.



\* Raise or lower the ball end by adding or subtracting washers here

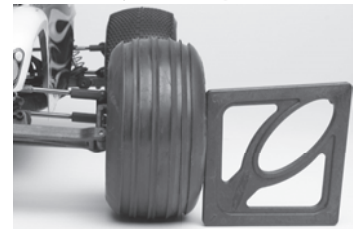

\* Testing camber with camber gauge

### Rear Camber Link

Changing the length of the camber link is considered a bigger step than adjusting the ball end height on the rear chassis brace. Shortening the camber link (or lowering the ball end) will give the rear end less roll and the car will tend to accelerate or "square up" better. Lengthening the camber link (or raising the ball end) will give the rear more roll and more cornering grip. Longer camber links are typically used on high grip tracks, while shorter links tend to work better on med-grip loose tracks. The kit setting is the best compromise of cornering grip and acceleration.



\* Raise or lower the ball end by adding or subtracting washers here

### Rear Camber

Camber describes the angle at which the tire and wheel rides when looked at from the back. Negative camber means that the tire leans inward at the top. A good starting camber setting is -1°. Use the included #1719 camber gauge to set your camber. Adding a small amount of positive camber, where the top of the tire is leaning out, will tend to improve straight-line acceleration on loose tracks.

### Ride Height

Ride height is the distance from the ground to the bottom of the chassis. The standard front ride height setting is with the front arms level (referred to as "arms level"). Check the ride height by lifting up the entire car about 8-12 inches off the bench and drop it. After the suspension "settles" into place, add or remove pre-load clips so that the left & right arms appear to be level.

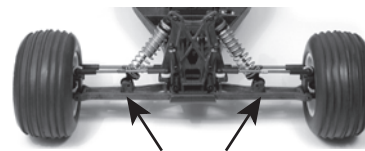

\* Front arms should be in a straight line when ride height is set at "arms level"

The rear ride height setting you should use most often is with the outdrive, driveshaft, and axles all on the same imaginary horizontal line (referred to as "bones level"). Check the ride height by lifting up the entire car about 8-12 inches off the bench and drop it. After the suspension "settles" into place, add or remove pre-load clips so that the left & right driveshafts appear to be level.

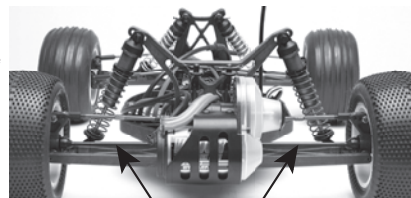

\* Dogbones should be in a straight line when ride height is set at "dogbones level"

### Wheelbase Adjustment

You have three options for rear hub spacing, Forward, Middle, & Back. The kit setting provides the most rear traction, and will be used most often. For improved handling in bumps or rhythm sections, try moving the hubs to the Middle or Back position. This can also make the car handle better in 180° turns.

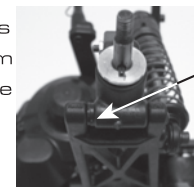

\* Spacers to the rear will place hubs forward, shortening the wheelbase

### Anti-Roll bar

The optional #9635 rear anti-roll bar kit (also called the "swaybar") allows you to add roll resistance to the rear end with minimal effect on handling over bumps and jumps. It is an especially helpful tuning item on high-grip tracks (try the gold bar). The silver and black anti-roll bars are typically used on medium-grip loose tracks.

# T4.1

**:: Driver:** Team Associated **:: Date:** \_\_\_\_\_  
**:: Track:** \_\_\_\_\_  
**:: Event:** \_\_\_\_\_

## Setup Sheet for Team Associated's T4.1

**Rev. 1**

### :: Front End

camber: -1

washers: 1

toe: 0

ride height: 30mm

axle height

bump steer spacer:

up  middle  down

caster

20°  25°  30°

### :: Rear End

camber: -1

washers: \_\_\_\_\_

anti-squat

std  other

ride height: 29mm

rear hub carriers

std  0°  0.5°  1°

wheel base

long  medium  short

anti-roll bar

none  black (soft)  silver (med)  gold (hard)

### :: Front Shocks

spring: silver piston: #2  
 shock oil: 30 wt limiter: 2

### :: Rear Shocks

spring: green piston: #1  
 shock oil: 30 wt limiter: 2

### :: Electronics

motor & wind: \_\_\_\_\_  
 pinion: \_\_\_\_\_  
 spur gear: \_\_\_\_\_  
 batteries: \_\_\_\_\_  
 battery placement: \_\_\_\_\_

radio: \_\_\_\_\_  
 throttle / brake epa: \_\_\_\_\_  
 throttle / brake expo: \_\_\_\_\_  
 esc: \_\_\_\_\_ throttle profile: \_\_\_\_\_  
 initial brake: \_\_\_\_\_ drag brake: \_\_\_\_\_  
 servo: \_\_\_\_\_ steering expo: \_\_\_\_\_

### :: Other

body: \_\_\_\_\_  
 notes: \_\_\_\_\_

### :: Differential

gear differential  fluid: black grease  
 ball differential

### :: Front Tires

tire: \_\_\_\_\_  
 compound: \_\_\_\_\_  
 insert: \_\_\_\_\_  
 wheel: \_\_\_\_\_

### :: Rear Tires

tire: \_\_\_\_\_  
 compound: \_\_\_\_\_  
 insert: \_\_\_\_\_  
 wheel: \_\_\_\_\_

### :: Race and Vehicle Comments

qualify: \_\_\_\_\_ main: \_\_\_\_\_ finish: \_\_\_\_\_ tq:   
 comments: \_\_\_\_\_  
 \_\_\_\_\_  
 \_\_\_\_\_  
 \_\_\_\_\_

### :: Track Info

smooth:  bumpy:  blue groove:   
 traction: high:  med:  low:   
 soft dirt:  grass:  clay:  wet:   
 dusty:  other: \_\_\_\_\_  
 \_\_\_\_\_  
 \_\_\_\_\_

# B4.1

**:: Driver:** Team Associated **:: Date:** \_\_\_\_\_  
**:: Track:** \_\_\_\_\_  
**:: Event:** \_\_\_\_\_

## Setup Sheet for Team Associated's B4.1

**Rev. 1**

### :: Front End

camber: -1

washers: 1

ABC

IO

toe: 0 ride height: 25mm

bump steer spacer: \_\_\_\_\_

axle height

up	<input type="checkbox"/>	20°	<input type="checkbox"/>
middle	<input checked="" type="checkbox"/>	25°	<input checked="" type="checkbox"/>
down	<input type="checkbox"/>	30°	<input type="checkbox"/>

caster

### :: Rear End

camber: -1

washers: 1

anti-squat  
std   
other

ABC

IO

rear hub carriers

std	<input checked="" type="checkbox"/>
0°	<input type="checkbox"/>
0.5°	<input type="checkbox"/>
1°	<input type="checkbox"/>

ride height: 25mm

wheel base

long	<input type="checkbox"/>
medium	<input type="checkbox"/>
short	<input checked="" type="checkbox"/>

anti-roll bar

none	<input checked="" type="checkbox"/>
black (soft)	<input type="checkbox"/>
silver (med)	<input type="checkbox"/>
gold (hard)	<input type="checkbox"/>

### :: Front Shocks

spring: brown piston: #1  
 shock oil: 30 wt limiter: 0

### :: Rear Shocks

spring: black piston: #1  
 shock oil: 30 wt limiter: 1

### :: Electronics

motor & wind: \_\_\_\_\_  
 pinion: \_\_\_\_\_  
 spur gear: \_\_\_\_\_  
 batteries: \_\_\_\_\_  
 battery placement: \_\_\_\_\_

radio: \_\_\_\_\_  
 throttle / brake epa: \_\_\_\_\_  
 throttle / brake expo: \_\_\_\_\_  
 esc: \_\_\_\_\_ throttle profile: \_\_\_\_\_  
 initial brake: \_\_\_\_\_ drag brake: \_\_\_\_\_  
 servo: \_\_\_\_\_ steering expo: \_\_\_\_\_

### :: Other

body: \_\_\_\_\_ wing: \_\_\_\_\_  
 notes: \_\_\_\_\_

### :: Differential

gear differential  fluid: black grease  
 ball differential

### :: Front Tires

tire: \_\_\_\_\_  
 compound: \_\_\_\_\_  
 insert: \_\_\_\_\_  
 wheel: \_\_\_\_\_

### :: Rear Tires

tire: \_\_\_\_\_  
 compound: \_\_\_\_\_  
 insert: \_\_\_\_\_  
 wheel: \_\_\_\_\_

### :: Race and Vehicle Comments













qualify: \_\_\_\_\_ main: \_\_\_\_\_ finish: \_\_\_\_\_ tq:   
 comments: \_\_\_\_\_  
 \_\_\_\_\_  
 \_\_\_\_\_  
 \_\_\_\_\_

### :: Track Info





smooth:  bumpy:  blue groove:   
 traction: high:  med:  low:   
 soft dirt:  grass:  clay:  wet:   
 dusty:  other: \_\_\_\_\_  
 \_\_\_\_\_  
 \_\_\_\_\_

:: Hardware - 1:1







**socket head (shcs)**

-  4-40 x 1/4 (6285)
-  4-40 x 3/8 (6924)  
w/hole (6929)
-  4-40 x 1/2 (6925)
-  4-40 x 5/8 (6926)
-  4-40 x 3/4 (6927)
-  4-40 x 7/8 (7738)
-  4-40 x 1 (6928)
-  4-40 x 1 1/4 (6913)
-  4-40 x 1 3/4 (9833)
-  5-40 x 7/16 (9643)
-  5-40 x 9/16 (9644)
-  5-40 x 3/4 (9835)



**flat head (fhcs)**

-  2.5x6mm (4675)
-  4-40 x 3/8 (6292)
-  4-40 x 1/2 (6922)
-  4-40 x 5/8 (6915)
-  5-40 x 1/2 (9269)

**button head (bhcs)**

-  2-56 x 1/8 (9645)
-  2-56 x 5/16 (4334)
-  4-40 x 5/16 (6919)
-  4-40 x 3/8 (6917)
-  4-40 x 7/16 (2221)
-  3x6mm (31531)

**setscrews**

-  3 x 3mm (25225)
-  4-40 x 1/2 (9170)
-  5-40 x 1/8 (3862)

**ball bearings**

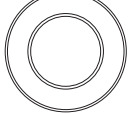
-  3/16 x 3/8 (3977)
-  10 x 16mm (9832)







**shims & washers**



-  ballstud washer (9630)
-  .03 nylon washer (4187)
-  gold washer (7337)
-  3/16 axle shim (7368)
-  #4 aluminum washer (6936)
-  5 x 9.5mm shim (9830)  
gear diff outdrives
-  servo saver shim (9610)  
servo saver hardware (lower)
-  servo saver shim (9610)  
servo saver hardware (upper)
-  5 x 14mm shim (9829)  
diff rebuild

**ballstuds**

-  black .20" (3981)
-  black .30" (3983)
-  silver .20" (6276)
-  silver .30" (6277)

**nuts (lock/plain)**

-  4-40 small plain nut (7260)
-  3/16 aluminum locking nut (4449)
-  shock mount nut (6472)
-  4-40 nut (6295)
-  5-40 lock nut (6629)
-  8-32 aluminum lock nut (9834)

Servo Chart	<b>STEERING SERVO TYPE</b>		<b>#7336 SPACER</b>	<b>#9180 SERVO ARM</b>
<b>1 FIND YOUR SERVO TYPE</b>	<b>1</b> (Steering servo is sold separately) <b>NOT ALL SERVOS ARE LISTED</b>		<b>2</b>	<b>3</b>
	<b>Associated Electrics / XP</b> AE SHV1504MG, DS1015, DS1313 <b>Airtronics</b> 94102 <b>Airtronics</b> 94738, 94157, 94158, 94257, 94258, 94357, 94358, 94452, 94453, 94751, 94755		thin spacer	<b>F</b>
<b>2 FIND YOUR SPACER(S)</b>	<b>Hitec</b> HS-5625MG, HS-5645MG, HS-625MG, HS-645MG <b>Hitec</b> HS-303, HS-300BB, HS-945MG, HS-925MG, HS-5945MG, HS-5925MG, HS-525MG, HS-525BB, HS-425BB, HS-422 <b>JR</b> Z4725, Z4750, Z2750, Z8450, Z8550, NES-4750 <b>JR</b> Z250, Z550		no spacer	<b>H</b>
			thin spacer	<b>H</b>
<b>3 SELECT YOUR SERVO HORN</b>	<b>Futaba</b> S9204, S9250, S9450, S148 <b>Futaba</b> S3003, S9202, S9101 <b>Futaba</b> S9404 <b>KO</b> PS-401, PS-2001, PS-2004, PS-2015, PS-2173, PS-2174, PS-2123, PS-2143, PS-2144		no spacer	<b>F</b>
			thin spacer	<b>F</b>
			thin spacer	<b>J</b>



# T4.1

**:: Driver:** \_\_\_\_\_ **:: Date:** \_\_\_\_\_  
**:: Track:** \_\_\_\_\_  
**:: Event:** \_\_\_\_\_

Setup Sheet for Team Associated's T4.1

**Rev. 1**

## :: Front End

camber: \_\_\_\_\_

washers: \_\_\_\_\_

ABC

IO

toe: \_\_\_\_\_ ride height: \_\_\_\_\_

bump steer spacer: \_\_\_\_\_

axle height up  middle  down

caster 20°  25°  30°

## :: Rear End

camber: \_\_\_\_\_

washers: \_\_\_\_\_

anti-squat std  other

ABC

IO

rear hub carriers std  0°  0.5°  1°

ride height: \_\_\_\_\_

wheel base long  medium  short

anti-roll bar none  black (soft)  silver (med)  gold (hard)

## :: Front Shocks

spring: \_\_\_\_\_ piston: \_\_\_\_\_  
 shock oil: \_\_\_\_\_ limiter: \_\_\_\_\_

## :: Rear Shocks

spring: \_\_\_\_\_ piston: \_\_\_\_\_  
 shock oil: \_\_\_\_\_ limiter: \_\_\_\_\_

## :: Electronics

motor & wind: \_\_\_\_\_  
 pinion: \_\_\_\_\_  
 spur gear: \_\_\_\_\_  
 batteries: \_\_\_\_\_  
 battery placement: \_\_\_\_\_

radio: \_\_\_\_\_  
 throttle / brake epa: \_\_\_\_\_  
 throttle / brake expo: \_\_\_\_\_  
 esc: \_\_\_\_\_ throttle profile: \_\_\_\_\_  
 initial brake: \_\_\_\_\_ drag brake: \_\_\_\_\_  
 servo: \_\_\_\_\_ steering expo: \_\_\_\_\_

## :: Other

body: \_\_\_\_\_  
 notes: \_\_\_\_\_

## :: Differential

gear differential fluid:  \_\_\_\_\_  
 ball differential:  \_\_\_\_\_

## :: Front Tires

tire: \_\_\_\_\_  
 compound: \_\_\_\_\_  
 insert: \_\_\_\_\_  
 wheel: \_\_\_\_\_

## :: Rear Tires

tire: \_\_\_\_\_  
 compound: \_\_\_\_\_  
 insert: \_\_\_\_\_  
 wheel: \_\_\_\_\_

## :: Race and Vehicle Comments

qualify: \_\_\_\_\_ main: \_\_\_\_\_ finish: \_\_\_\_\_ tq:

comments: \_\_\_\_\_  
 \_\_\_\_\_  
 \_\_\_\_\_  
 \_\_\_\_\_

## :: Track Info

smooth:  bumpy:  blue groove:

traction: high:  med:  low:

soft dirt:  grass:  clay:  wet:

dusty:  other: \_\_\_\_\_  
 \_\_\_\_\_  
 \_\_\_\_\_

# B4.1

**:: Driver:** \_\_\_\_\_ **:: Date:** \_\_\_\_\_  
**:: Track:** \_\_\_\_\_  
**:: Event:** \_\_\_\_\_

Setup Sheet for Team Associated's B4.1

**Rev. 1**

## :: Front End

camber: \_\_\_\_\_

washers: \_\_\_\_\_

ABC

IO

toe: \_\_\_\_\_ ride height: \_\_\_\_\_

bump steer spacer: \_\_\_\_\_

axle height

up  20°

middle  25°

down  30°

caster

20°

25°

30°

## :: Rear End

camber: \_\_\_\_\_

washers: \_\_\_\_\_

anti-squat

std

other  ABC

IO

rear hub carriers

std

0°

0.5°

1°

ride height: \_\_\_\_\_

wheel base

long

medium

short

anti-roll bar

none

black (soft)

silver (med)

gold (hard)

## :: Front Shocks

spring: \_\_\_\_\_ piston: \_\_\_\_\_

shock oil: \_\_\_\_\_ limiter: \_\_\_\_\_

## :: Rear Shocks

spring: \_\_\_\_\_ piston: \_\_\_\_\_

shock oil: \_\_\_\_\_ limiter: \_\_\_\_\_

## :: Electronics

motor & wind: \_\_\_\_\_

pinion: \_\_\_\_\_

spur gear: \_\_\_\_\_

batteries: \_\_\_\_\_

battery placement: \_\_\_\_\_

radio: \_\_\_\_\_

throttle / brake epa: \_\_\_\_\_

throttle / brake expo: \_\_\_\_\_

esc: \_\_\_\_\_ throttle profile: \_\_\_\_\_

initial brake: \_\_\_\_\_ drag brake: \_\_\_\_\_

servo: \_\_\_\_\_ steering expo: \_\_\_\_\_

## :: Other

body: \_\_\_\_\_

notes: \_\_\_\_\_

## :: Differential

gear differential fluid:  \_\_\_\_\_

ball differential:  \_\_\_\_\_

## :: Front Tires

tire: \_\_\_\_\_

compound: \_\_\_\_\_

insert: \_\_\_\_\_

wheel: \_\_\_\_\_

## :: Rear Tires

tire: \_\_\_\_\_

compound: \_\_\_\_\_

insert: \_\_\_\_\_

wheel: \_\_\_\_\_

## :: Race and Vehicle Comments

qualify: \_\_\_\_\_ main: \_\_\_\_\_ finish: \_\_\_\_\_ tq:

comments: \_\_\_\_\_

\_\_\_\_\_

\_\_\_\_\_

\_\_\_\_\_

## :: Track Info

smooth:  bumpy:  blue groove:

traction: high:  med:  low:

soft dirt:  grass:  clay:  wet:

dusty:  other: \_\_\_\_\_

\_\_\_\_\_

\_\_\_\_\_

**:: For more setups, visit [www.RC10.com](http://www.RC10.com) and click on 'Racing'**